

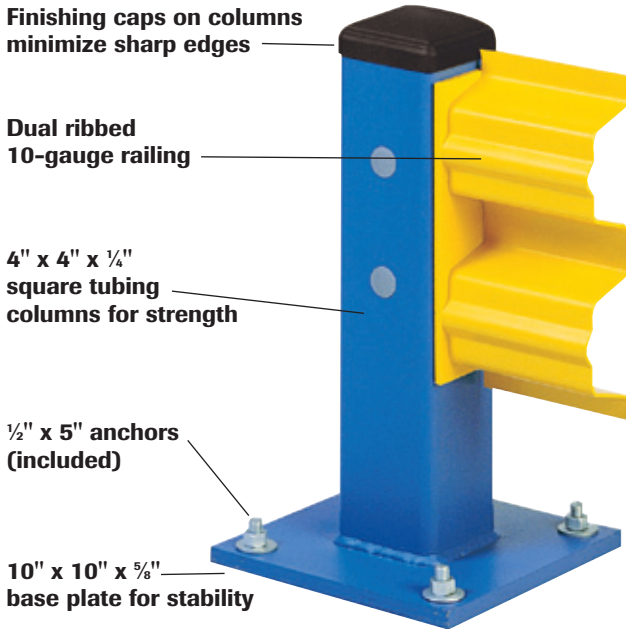

Guard-Rail Systems

Protective Guard-Rail Systems

Reduce machinery downtime, inventory losses and work-related injuries with the Protective Guard Rail System. Heavy duty columns and rails form protective barriers for in-plant work areas, office walls, doorways, building passages and driveways.



Pre-Engineered Single Rail Sections

For basic systems, simply start with the appropriate Starter rail, then add Add-Ons as necessary. All rails are 12" high, with 18" high columns.



Cat. No.	Nominal Length*	Beam Length*	Type
40100	10'	9'8"	Starter
40110	10'	9'8"	Add-On
40120	6'	5'8"	Starter
40230	6'	5'8"	Add-On

*NOTE: Lengths shown are center to center.

Color Selection

- TY** Safety Yellow
Rails and Accessories
- TB** Blue
Column Posts

Guard-Rail Components/Options



Guard Rails

Use with columns to custom-build protective barriers for your operations. All lengths shown are 12" high.

- No. 40004** - 4' long nominal, 3'8" actual
- No. 40005** - 5' long nominal, 4'8" actual
- No. 40006** - 6' long nominal, 5'8" actual
- No. 40007** - 7' long nominal, 6'8" actual
- No. 40008** - 8' long nominal, 7'8" actual
- No. 40010** - 10' long nominal, 9'8" actual



Column Posts

Use single columns for single rail applications, dual for two rails, and triple for full 42" high protection.

- (A) No. 40003** - Triple, 42" high
- (B) No. 40002** - Dual, 42" high
- (C) No. 40000** - Single, 18" high



Bollards

Use to protect dock doorways and building passages. Also great to direct traffic flow. 42" high, 6 5/8" diam. x 1/4" thick.

No. 40026



Flared Ends

Deflects vehicular traffic impact. 10 ga. 10" high, 9 1/8" long.

No. 40024



Corner Guards

Add protection for office and wall corners. Full gussets to withstand impact. 1/4" thick x 17"D x 18"H.

No. 40020