

Lyon Workspace Products

Bulk Storage Rack Specifications

Box Post Uprights

Knocked Down

All posts are punched on 1-1/2" centers to accept either clip attachment or bolt attachment. Each upright shall consist of two 14-gauge, hot rolled, formed steel "box posts" 1-3/4" x 1-13/16" with two 4-1/16" x 12-gauge ladder braces on uprights of 96" or less. 120" and 144" uprights require three ladder braces. Ladder braces contain tangs, which engage into square slots of post. Ladder braces are also secured to posts with thread cutting screws.

Welded

All posts are punched on 1-1/2" centers to accept either clip attachment or bolt attachment. Each upright shall consist of two 14-gauge, hot rolled, formed steel "box posts" 1-3/4" x 1-13/16" and diagonal and horizontal bracing made of 3/4" x 1-1/2" x 20-gauge welded tubing. All components parts will be mig-welded to form a continuous upright assembly.

Shelf Clips

Integration shelf clips used with solid 8000 series shelves. Four clips required per shelf. Clips are 12-gauge, hot rolled, and one-piece construction.

Beams

Heavy Duty

14-gauge formed "Z" shaped member, hot rolled steel. Overall height of beam is 3-5/8", which includes a 5/8" step at top of beam. Top flange of beam punched with slots for front to back supports. Beam support clips are mig-welded to beam member. Beam clips are 12-gauge hot-rolled steel. Clips have integral three prong fingers that allow for beams to be secured to post without hardware. Clips have integral fold in lock tab that can be bent in act as locking device prohibiting removal or dislodging of beam from post.

Extra Heavy Duty

12-gauge formed "Z" shaped member, hot rolled steel. Overall height of beam is 4-5/8", which includes a 5/8" step at top of beam. Top flange of beam punched with slots for front to back supports. Beam support clips are mig-welded to beam member. Beam clips are 12-gauge hot-rolled steel. Clips have integral three prong fingers that allow for beams to be secured to post without hardware. Clips have integral fold in lock tab that can be bent in act as locking device prohibiting removal or dislodging of beam from post.

Low Profile

12-gauge formed "Z" shaped member, hot rolled steel. Overall height of beam is 2", which includes a 5/8" step at top of beam. Top flange of beam punched with slots for front to back supports. Beam support clips are mig-welded to beam member. Beam clips are 12-gauge hot-rolled steel. Clips have integral three prong fingers that allow for beams to be secured to post

Lyon Workspace Products

Bulk Storage Rack Specifications

without hardware. Clips have integral fold in lock tab that can be bent in act as locking device prohibiting removal or dislodging of beam from post.

Automotive Duty Tire Beam

14-gauge formed profile shape member, hot rolled steel. Overall height of beam is 3-5/8" with flat surface where tire contacts beam and helps to prevent tire deformity. Beam support clips are mig-welded to beam member. Beam clips are 12-gauge hot-rolled steel. Clips have integral three prong fingers that allow for beams to be secured to post without hardware. Clips have integral fold in lock tab that can be bent in act as locking device prohibiting removal or dislodging of beam from post.

Truck Duty Tire Beam

12-gauge formed profile shape member, hot rolled steel. Overall height of beam is 4-5/8" with flat surface where tire contacts beam and helps to prevent tire deformity. Beam support clips are mig-welded to beam member. Beam clips are 12-gauge hot-rolled steel. Clips have integral three prong fingers that allow for beams to be secured to post without hardware. Clips have integral fold in lock tab that can be bent in act as locking device prohibiting removal or dislodging of beam from post.

Shelves And Solid Decking

Medium Duty (M) Industrial Shelves

22-gauge with front and rear "Box W" formation. The front and rear "Box W" formation is not less than 1-11/64" x 27/32" x 1-1/8" with a 9/16" return flange spot-welded to bottom surface of the shelf. The 27/32" portion of the "Box W" formation shall have a 10-degree bend in the center for additional strength and rigidity. The front and rear flanges of the shelf shall be punched to accept bin fronts, label holders, and other accessories. Ends are to be flanged not less than 1-11/64" with a 90 degree return flange of not less than 5/8". All corners are lapped and welded. All shelves are punched on 3" centers for divider attachment. The front and rear flanges of the shelf are to be embossed with "22 GA". Shelves also punched at four corners for bolting to uprights.

Heavy Duty (H) Industrial Shelves

20-gauge with front and rear "Box W" formation. The front and rear "Box W" formation is not less than 1-11/64" x 27/32" x 1-1/8" with a 9/16" return flange spot-welded to bottom surface of the shelf. The 27/32" portion of the "Box W" formation shall have a 10-degree bend in the center for additional strength and rigidity. The front and rear flanges of the shelf shall be punched to accept bin fronts, label holders, and other accessories. Ends are to be flanged not less than 1-11/64" with a 90 degree return flange of not less than 5/8". All corners are lapped and welded. All shelves are punched on 3" centers for divider attachment. The front and rear flanges of the shelf are to be embossed with "20 GA". Shelves also punched at four corners for bolting to uprights.

Lyon Workspace Products

Bulk Storage Rack Specifications

Extra Heavy Duty (X) Industrial Shelves

18-gauge with front and rear “Box W” formation. The front and rear “Box W” formation is not less than 1-11/64" x 27/32" x 1-1/8" with a 9/16" return flange spot-welded to bottom surface of the shelf. The 27/32" portion of the “Box W” formation shall have a 10-degree bend in the center for additional strength and rigidity. The front and rear flanges of the shelf shall be punched to accept bin fronts, label holders, and other accessories. Ends are to be flanged not less than 1-11/64" with a 90 degree return flange of not less than 5/8". All corners are lapped and welded. All shelves are punched on 3" centers for divider attachment. The front and rear flanges of the shelf are to be embossed with “18 GA”. Shelves also punched at four corners for bolting to uprights.

Traditional Industrial Shelves

18-gauge with front and rear flanged down not less than 1-11/64" with return flanges of not less than 3/8" at approximately 10 degrees and punched to accommodate label holder and accessories. Ends are to be flanged not less than 1-11/64" with a 90 degree return flange of not less than 5/8". All corners are lapped and welded. All shelves are punched on 3" centers for divider attachment. The front and rear flanges of the shelf are to be embossed with “18 GA”. Must request punching for bolting of shelves to uprights for 12", 18", 24", and 36" deep.

Front To Back Supports

12 Ga hot-rolled member formed to a height of 1-5/16" and top flange of 1". Ends of support have a 5/8" down turned formation that allows for insertion into pre-punched slots in beam member. Supports help minimize beam rotation under heavy loads.

Anchoring Foot

Anchoring plate is 2" x 3-1/2" x 10-gauge plate punched with one 1/2" diameter hole for floor anchoring by means of 7/16" diameter wedge anchor (not provided). A 12-gauge attachment channel 3-7/32" high is welded to the floor plate. BSR post is to slide over the 12-gauge channel and is secured with two 1/4" x 1/2" thread cutting screws.

Back To Wall Support

Bracket assembly and adjustable band is made from 12-gauge hot-rolled steel. Bolts to upright post and to wall to maintain rack stability. Adjustable from 12" to 17-1/4".

Back To Back Support

Bracket assembly and adjustable band is made from 12-gauge hot-rolled steel. Secures back-to-back sections of BSR rack to maintain rack stability and spacing without interfering with storage space. Adjustable from 12" to 17-1/4".

Lyon Workspace Products Bulk Storage Rack Specifications

Rack Dimensions For Attached Drawing On Next Page

| Nominal Rack Depth | Rack Depth "A" | Inside Depth "B" | Nominal Width | Actual Width | "D" | "E" |
|-----------------------|-------------------|---------------------|------------------|-----------------|-----------|-----------|
| 15" | 15-9/16" | 15-1/4" | 48" | 48-1/2" | 50-15/32" | 48-23/32" |
| 18" | 18-9/16" | 18-1/4" | 60" | 60-1/2" | 62-15/32" | 60-23/32" |
| 24" | 24-9/16" | 24-1/4" | 72" | 72-1/2" | 74-15/32" | 72-23/32" |
| 30" | 30-9/16" | 30-1/4" | 84" | 84-1/2" | 86-15/32" | 84-23/32" |
| 36" | 36-9/16" | 36-1/4" | 96" | 96-1/2" | 98-15/32" | 96-23/23" |
| 42" | 42-9/16" | 42-1/4" | | | | |
| 48" | 48-9/16" | 48-1/4" | | | | |

Lyon Workspace Products

Bulk Storage Rack Specifications

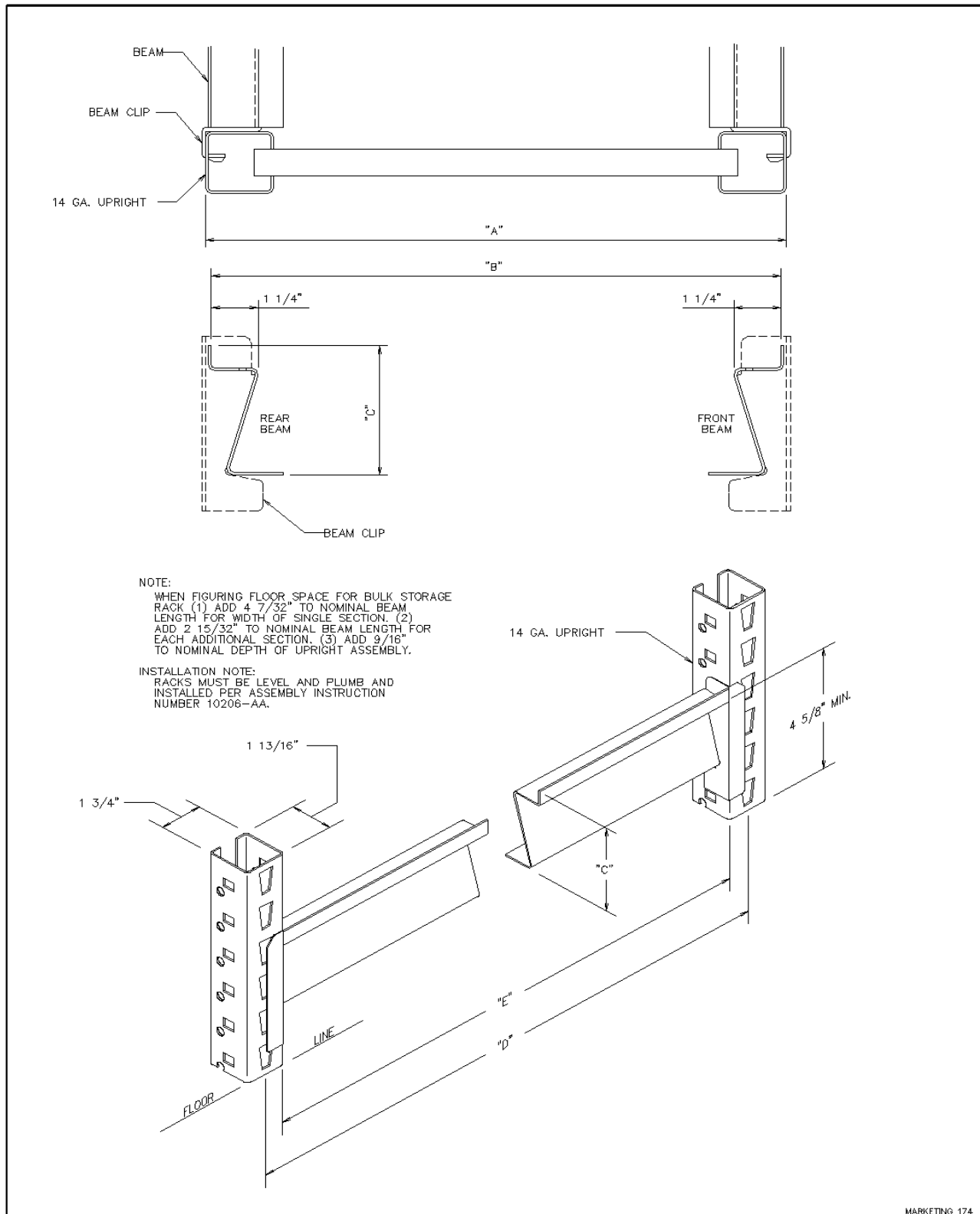

MARKETING 174