

GENERAL SPECIFICATIONS: Pallet Rack Effective September 2010 to Present

FRAME CONSTRUCTION

Column Material

- Columns shall be roll formed lipped channels, constructed out of ASTM A1011 coil steel with a minimum yield strength of 55,000 psi before forming. Manufacturer shall keep a copy of the steel strength certification.
- Fixtures used to fabricate the assembled frame shall be designed to remove all natural twist and camber from the column material.
- Ends of the columns that get welded to the base plate shall be square to within 1 degree.

Column Punching

Hole locations shall be placed as follows:

- Holes start at a location required to provide a nominal top of beam location that is on even 2 inch increments as measured from the top of the base plate.
- Holes are placed on 2" centers along the length of the column.
- Holes shall be teardrop shape.

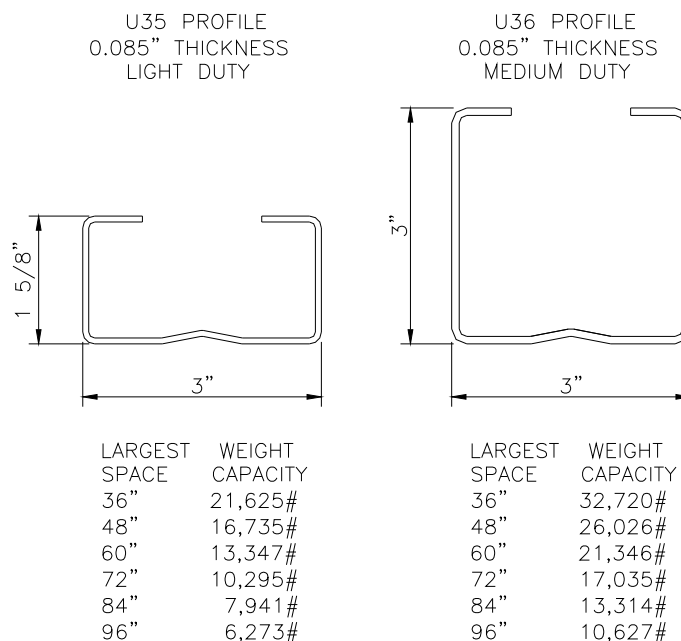

U26 PROFILE
0.102" THICKNESS
HEAVY DUTY

U06 PROFILE
0.128" THICKNESS
EXTRA HEAVY DUTY

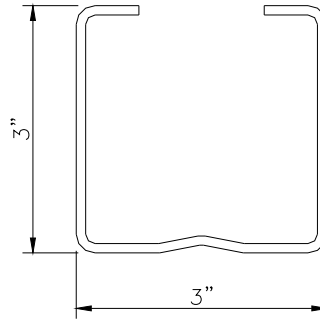
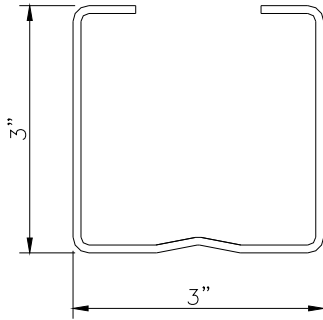

LARGEST SPACE	WEIGHT CAPACITY
36"	42,235#
48"	32,981#
60"	26,683#
72"	21,003#
84"	13,314#
96"	12,892#

LARGEST SPACE	WEIGHT CAPACITY
36"	52,180#
48"	40,665#
60"	32,790#
72"	25,684#
84"	19,868#
96"	15,741#

Base Plate

- Base plate shall be constructed from steel that has a minimum yield strength of 36000 psi.
- Base plates will be welded to the column
- Base plates that resist lateral seismic forces shall be welded in accordance with the requirements of the structural analysis performed for the project.
- Minimum leg of the fillet weld shall be 1/8".
- Standard plate size will be 3-1/4" x 5"

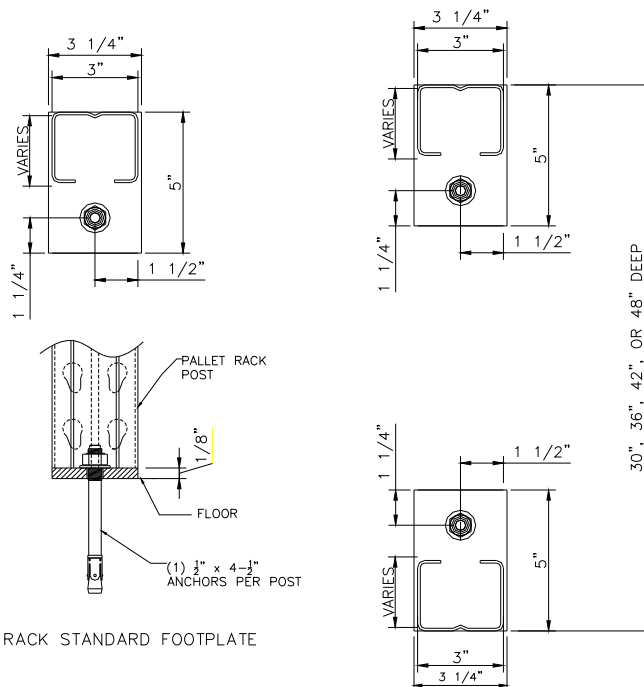

PALLET RACK STANDARD FOOTPLATE

Horizontal Bracing

- Horizontals shall be constructed typically from 2-1/4" x 1-1/2" cold formed lipped channels. Wall thickness of the channels shall be a minimum of 14 gauge. Steel shall be ASTM A1011 with a minimum yield strength of 45,000 psi before forming. Larger bracing may be used if required by the structural analysis.
- Vertical spacing of horizontal braces (also called panel spacing) shall be positioned as necessary to stabilize the column. The first panel shall start approximately 6" from floor to the top of the horizontal brace and be 48" in height. Refer to roll-formed panel spacing chart for standard dimensions. Frame loading conditions often require these panel spaces to be adjusted, so final locations of the horizontals must be consistent with the structural analysis.
- Horizontals shall be welded to the lips of the column with a full weld on 2 sides of the horizontal. Minimum weld size shall be 1/8".
- Under no circumstances should the welding have less capacity than that required by the structural analysis for the project.

Diagonal Bracing

- Diagonals shall be typically made from 2-1/4" x 1-1/2" cold formed lipped channels. Material to be ASTM A1011 with a minimum yield strength of 45,000 psi. Larger bracing may be used if required by the structural analysis.
- Diagonals shall be located in every panel of the upright assembly greater than 30". Panels without diagonals shall only be at the top of the upright assembly. Diagonals shall be welded directly to the column lips.
- Minimum weld size on the diagonals shall be 1/8".
- Under no circumstances should the welding have less capacity than that needed to fully develop the forces required by the structural analysis for the project.

STEP BEAMS

Step Tube

- Step beam material shall conform to ASTM A1011 and have a minimum yield strength of 55,000 psi, before forming of the tube. Increase in yield strength due to the cold forming process shall be allowed according to AISI A7.2.
- Step tubing shall be manufactured on a tube mill capable of "rolling square welding square". This process has better control of the straightness and twist of the final step tube. Straightness and twist is critical when step beams are intended to support decks.
- Tubing shall utilize seamless, induction welding technology. Stitch-welded, lap connections will not be acceptable.

- Twist and straightness in the tubing is not to exceed 0.041" in 36" on length.
- Cut lengths of tube to be within the tolerance of +0.0625", minus -0.0625". Fixturing of the beams should be set up to ensure that there is minimal growth in the rack system.
- Step size shall be 1-5/8" deep and 1" wide.
- Inside of the step to be set back 1-3/4" from the front face of the upright column.

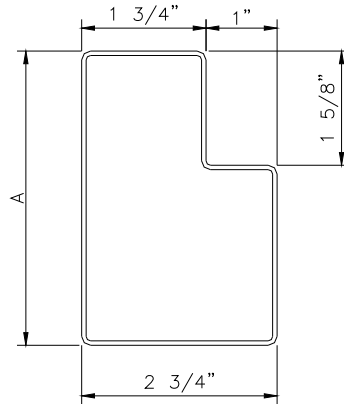

Profile Designation	A
250	2- $\frac{1}{2}$ "
300	3"
356	3- $\frac{9}{16}$ "
418	4- $\frac{3}{16}$ "
450	4- $\frac{1}{2}$ "
500	5"
550	5- $\frac{1}{2}$ "
600	6"

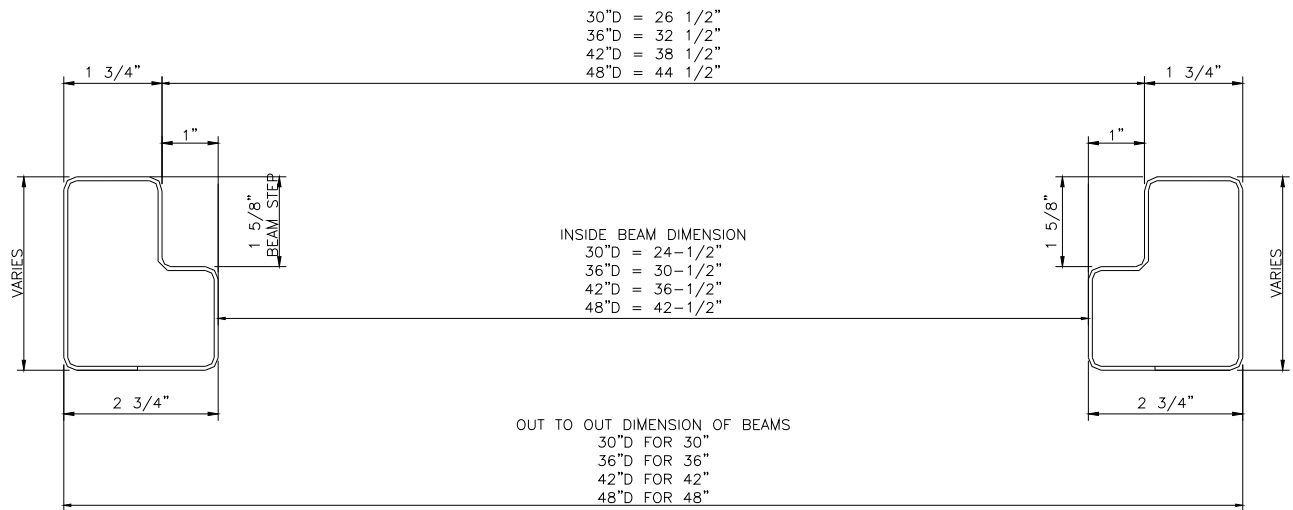

BEAM FRONT TO BACK DIMENSIONS

CONNECTION BRACKETS

- Connection brackets shall be manufactured from steel having a minimum yield strength of 36,000 psi.
- Connection brackets shall be designed to provide direct contact to the roll formed columns. The brackets shall be designed with 3 support pins for beams up to 5-1/2" in height. Connector bracket will be 6" tall. For beams 6.0" beam heights, the connection brackets shall have 4 pins and the bracket height will be 8".
- Bracket design shall conform to industry standards for shape and fit.
- Material thickness of the bracket shall be no less than 0.140".

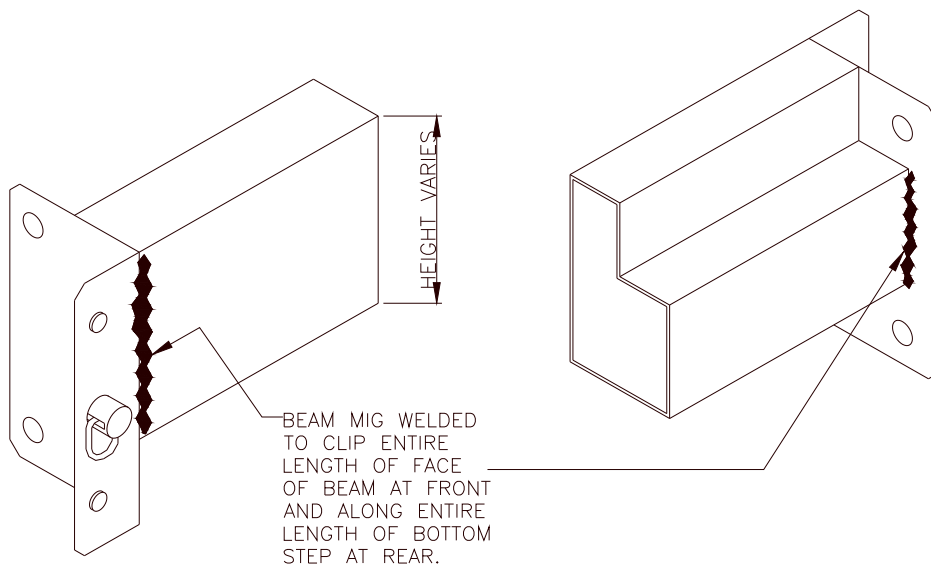

ANCHOR BOLTS

- Standard anchor bolt shall be $\frac{1}{2}$ " diameter by 3.75" long. Other anchors may be required due to seismic loading.
- Minimum anchor embedment depth shall be $2\frac{1}{4}$ "; deeper embedment may be required by the structural analysis.