

CAUTION

IT IS HIGHLY RECOMMENDED THAT THE LATCH-IN/LATCH-OUT MECHANISM BE UTILIZED ON ALL DRAWERS WHEN CASTERS ARE APPLIED TO CABINET. DRAWERS OF UNLOCKED, MOBILE CABINETS WITHOUT LATCH-IN/LATCH-OUT ON DRAWERS CAN OPEN ON UNLEVEL SURFACES, RESULTING IN CABINET TIPPING.

* MAXIMUM WEIGHT PER 5" CASTER IS 650lbs. (Total weight of cabinet and contents cannot exceed 2600lbs.)

* MAXIMUM WEIGHT PER 6" CASTER IS 700lbs. (Total weight of cabinet and contents cannot exceed 2800lbs.)

CABINET HANDLE INSTALLATION

Remove sufficient top drawers and carriers from the cabinet. Mark specific locations of drawers and carriers for reinstallation.

The cabinet handle can be mounted on either side of the cabinet. However, it is recommended that it be mounted on the left side of the cabinet opposite of the cabinet lock. After you decide which side to mount the handle, bend in and up the closure tabs on the upper side of the cabinet as shown in the owners manual.

Attach the handle loosely to the front of the cabinet with supplied fasteners. Repeat again at the rear of the cabinet and then tighten all fasteners.

Replace drawers and carriers into specific locations and check for proper drawer operation.

Peel off the supplied Warning Label backing and affix it to the side panel of the cabinet below the handle as shown.

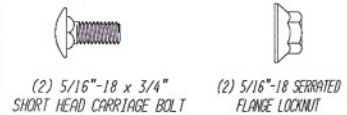
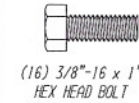
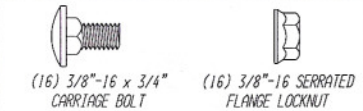
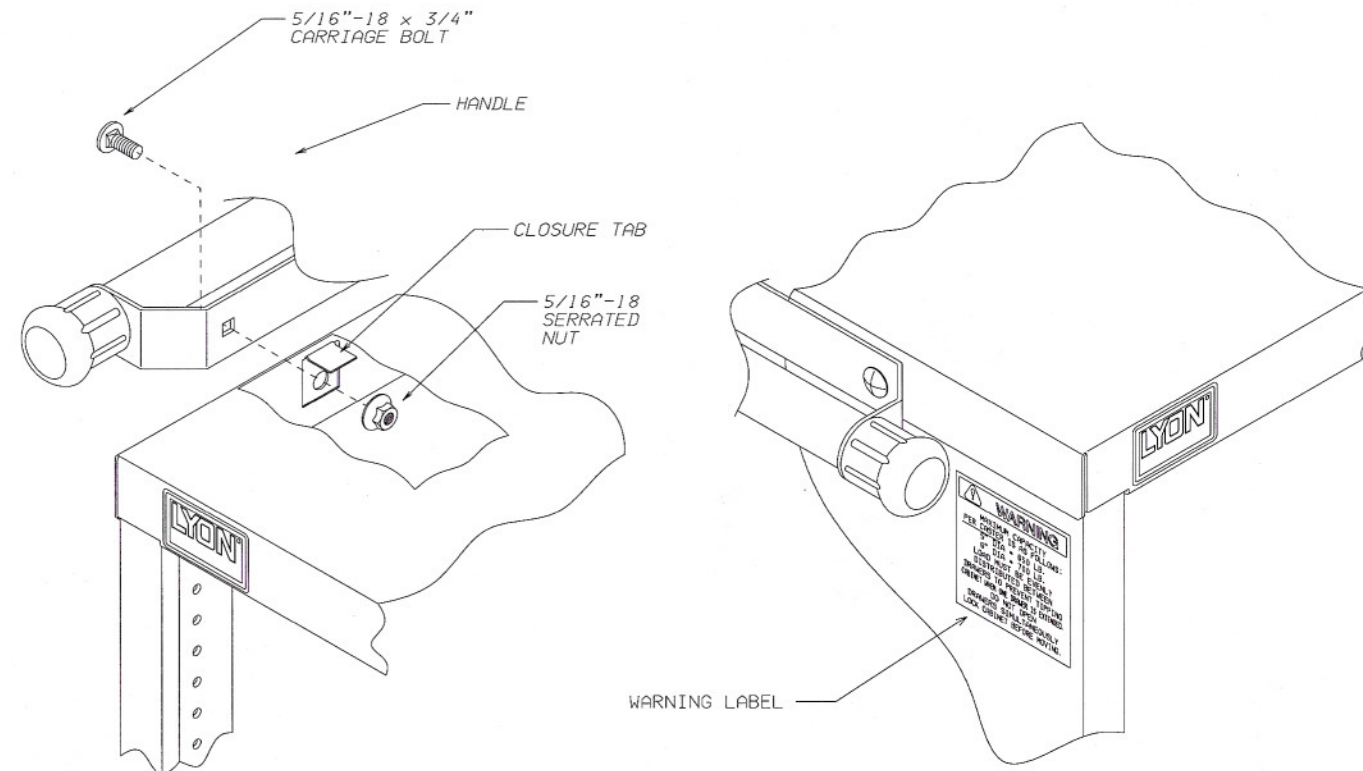

SUPPLIED FASTENERS

SYM	REVISION	ECN	DATE	BY
△	REVISED HANDLE	0539	03-17-07	RE
△	REVISED WARNING		11-19-02	RE
△	CARRIAGE BOLT WAS 1"	0393	01-06-00	RE
△	REVISED FOR NEW MDC CABINET	0376	10-18-99	RE
△	REVISED	0167	06-16-94	RE
△	REVISED HANDLE		10-16-92	RE
△	RELEASED		08-04-86	

NOTES:

- 1) ALL DIMENSIONS ARE INCHES
- 2) TOLERANCES (UNLESS OTHERWISE NOTED)
DECIMAL: .XX = ±.03
.XXX = ±.015
ANGULAR: = ±1°
- 3) REMOVE ALL SHARP EDGES AND BURRS

MATERIAL

RAW P/N	WEIGHT(LB)	FINISH:
100466	---	---
DATE	REDRAWN BY	CHECKED BY
08-04-86	RE	DV

LYON LYON METAL PRODUCTS
PO BOX 671 AURORA, IL 60507
(800) 323-0082 FAX: (800) 367-6681

MDC DESCRIPTION
INSTALLATION - HANDLE / CASTERS

SHEET	DWG NUMBER	REV
1	10203 AA	7

NOTICE: THIS IS A CONFIDENTIAL DISCLOSURE. LOANED BY LYON METAL PRODUCTS FOR REFERENCE PURPOSES ONLY

CASTER INSTALLATION FOR CABINETS WITH BASE CHANNELS

Attach the four (4) casters to the cabinet base channels using four (4) each of the 3/8-16 x 3/4" carriage bolts and serrated flange locknuts. See detail below. Be sure to attach the swivel casters on the same side of the cabinet as the cabinet handle and the rigid casters on the opposite side.

Follow instructions in the owners manual for attaching the base closure strip to the cabinet.

CASTER INSTALLATION FOR CABINETS WITHOUT BASE CHANNELS

Remove sufficient bottom drawers and carriers from the cabinet. Mark specific locations of drawers and carriers for reinstallation. Attach the casters to the caster plates using two (2) each of the 3/8-16 x 1" hex head bolts and serrated flange locknuts. Be sure to attach both swivel casters to one caster plate and the rigid casters to the other caster plate. See detail below. Now attach the swivel caster plate assembly and the rigid caster plate assembly to the cabinet bottom using the remaining hex head bolts and serrated flange locknuts. The clearance holes in the cabinet bottom will allow the caster plate assemblies to fit. Be sure to attach the swivel caster plate assembly on the same side of the cabinet as the cabinet handle and the rigid caster plate assembly on the opposite side.

Replace drawers and carriers into specific locations and check for proper drawer operation.

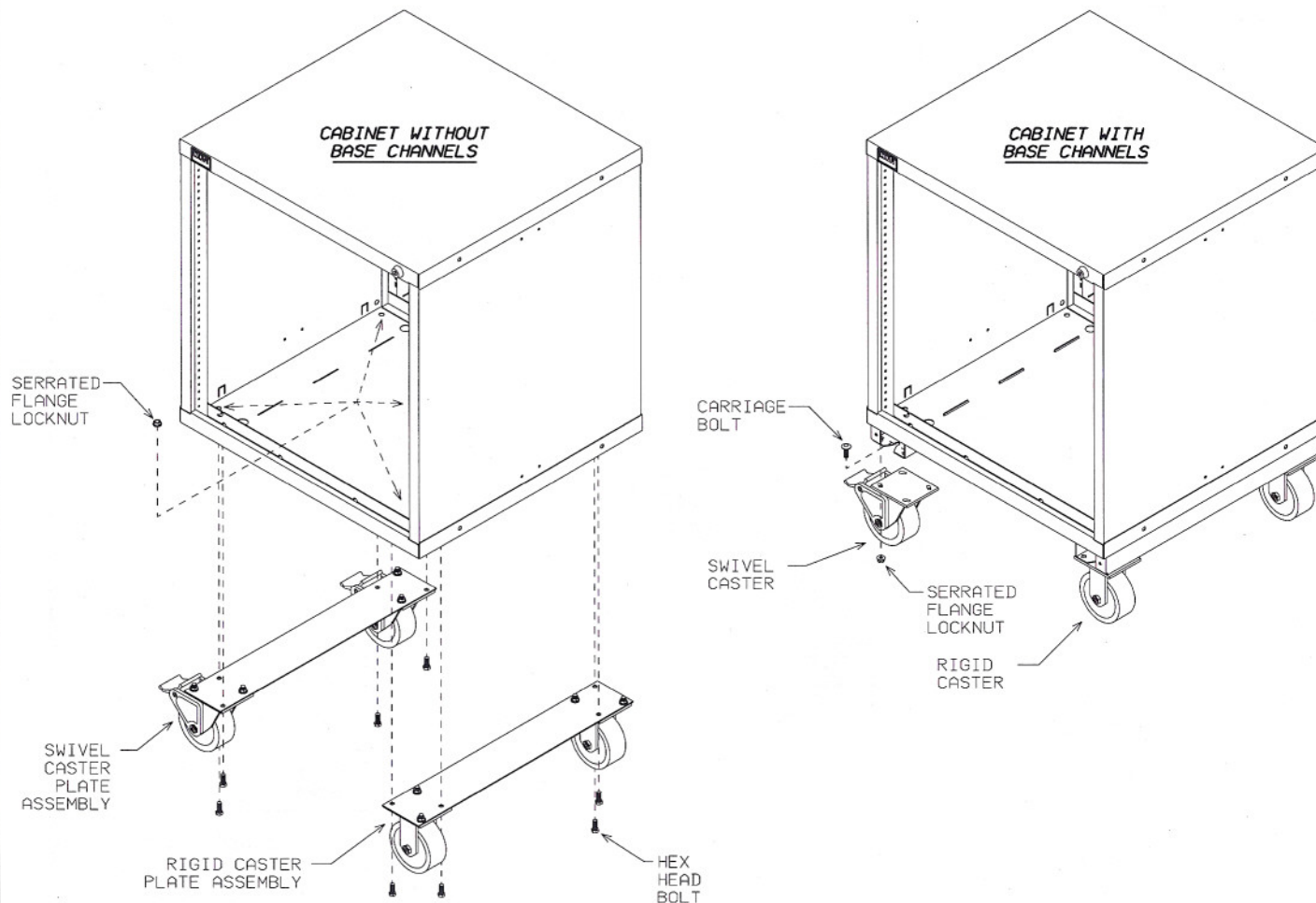

LYON		LYON METAL PRODUCTS PO BOX 671 AURORA, IL 60507 (800) 323-0082 FAX: (800) 367-6681	
MDC		DESCRIPTION INSTALLATION - HANDLE / CASTERS	
SHEET	DWG NUMBER	REV	
2	10203 AA	7	