



# OWNER'S MANUAL



## INDUSTRIAL CHAIR MODEL NO. 2024FGN

Save This Manual For  
Future Reference

### DESCRIPTION

The Lyon Industrial Chair is ergonomically engineered for durability, support, comfort and long wear in tough environments. The pneumatic lift allows 8" of adjustment while you are seated and an additional 10" of manual adjustment by repositioning the lift. The footrests are polyurethane molded over steel. The five-leg base is one-piece construction of welded steel tube. The five-leg base ensures maximum stability, especially critical at high height ranges. Five high-impact, non-marking, oil-resistant glides withstand harsh environments. Casters are available as an option.

### GENERAL SAFETY INSTRUCTIONS

Do not stand on seat. Chair must be on level surface to ensure proper stability. Only use chair when fully assembled. Periodically check fasteners and tighten securely as needed. Never use chair if it does not perform according to this manual. Warranty may be void if chair is used while damaged. Immediately call and report any problems (see How to Order Repair Parts) and always give the serial number from label under seat.

**CAUTION:** Allow for optimum support. Never position lift higher than the bottom of the base tube. Always leave at least 1/2" clearance between the bottom of the lift and the floor.

### ASSEMBLY

1. Unpack chair. Check all parts against parts list before beginning assembly. Allow parts to warm to room temperature prior to assembly.
2. Turn base upside down. Locate the pairs of holes between adjacent legs near curved portion. Slide footrest (Key No. 5) between legs. Position footrest near curve about 1" from holes in legs. Slide L-bolts (Key No. 3) into holes in legs, so bolt hook is pointing towards holes in bottom of footrest. Slide footrest onto bolt hooks. Secure each L-bolt with hex nuts (Key No. 4). Repeat process for lowest footrest.
3. Place glide onto base leg and tap glide down (Key Nos. 1 and 2) using a rubber mallet. Glides should fit snug. Glides are easier to install if they are slightly expanded. Use blow dryer or warm water (dry thoroughly) to expand glides. Be sure glide is inserted fully onto leg to ensure stability of base. Repeat for other four glides. Turn base right side up.

4. Slide pneumatic lift (Key No. 9) into base (loosen base knob if necessary) with pneumatic lift piston pointed away from legs. Insert stop ring (Key No. 8) into groove in end of pneumatic lift. To install stop ring, gently peel one end of stop ring away from rest of coil. Place end in groove on pneumatic lift. Slide fingers along coil, guiding strip into groove, until stop ring is fully installed.
5. Position pneumatic lift about half way down in base. Tighten base knob (Key No. 6) to secure pneumatic lift.
6. Install seat assembly (Key No. 21) on top of lift. Align hole in control assembly (Key No. 13) with top of lift. Push down on seat to insert firmly together. Underneath the seat is a handle (Key No. 11) to adjust height of lift.
7. Slide lower backstem (Key No. 18) into slot at back of control assembly. Use a standard screwdriver to depress push button near end of lower backstem. Slide backstem until push button locks in control. Remove knob with cone point (Key No. 17) from parts bag. Thread knob into control and tighten to secure lower backstem in proper position.
8. Slide upper backstem from backrest assembly (Key No. 20) into lower backstem. Tighten knob with flat point (Key No. 19) to secure backrest in place.
9. Make final chair adjustments following instructions on page 4.

### MAINTENANCE

The pneumatic lift is permanently lubricated at the factory and needs no further lubrication. **Never lubricate the pneumatic lift.** This could damage the lift and void your warranty.

Do not remove clip from bottom of lift. Call for immediate assistance if clip is missing or damaged.

#### HOW TO ORDER REPAIR PARTS

When ordering repair parts or reporting problems, always give the following information:

NAME OF ITEM	MODEL NUMBER
Industrial Chair	2024FGN
PART DESCRIPTION	PART NUMBER

All parts listed may be ordered from your local Lyon Dealer or Lyon Workspace Products, P. O. Box 671, Aurora, IL 60507 800/323-0082 or 630/892-8941

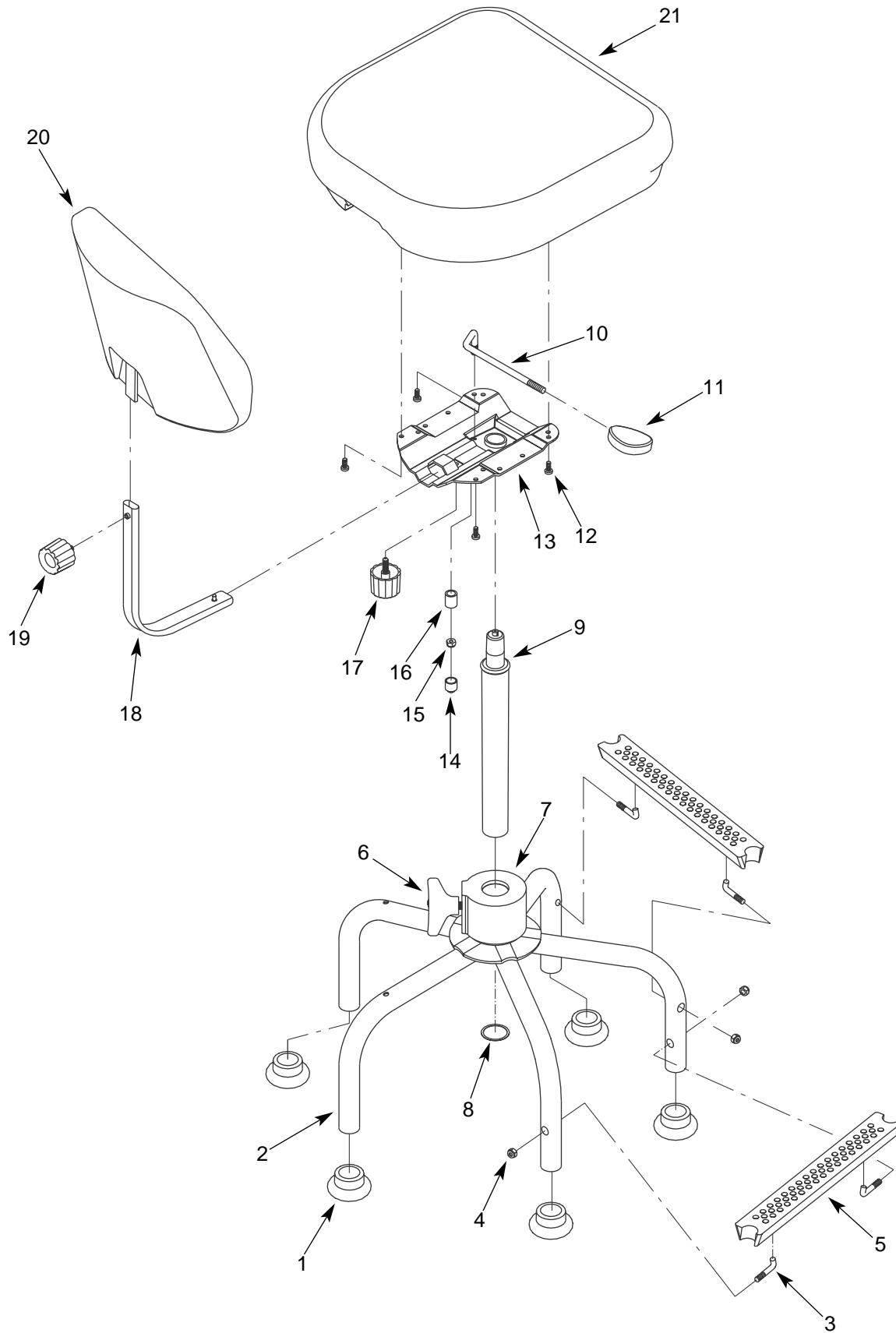

KEY NO.	DESCRIPTION	QTY	PART NO.
1	Glide	5	09019.00
2	Base	1	01254.03
3	L-bolt	4	01257.00
4	8-1.25mm Fiber Hex Nut	4	01256.00
5	Footrest	2	01258.05
6	Base Knob	1	01751.15
7	Base Cover	1	10202.00
8	Stop Ring	1	01754.00
9	Pneumatic Lift	1	01753.50
10	Lever	1	09041.03
11	Handle	1	03394.02
12	6-1.0 x 16mm Pan Head Screw	4	03713.00
13	Control Assembly (includes Key Nos. 10, 11 and 13-16)	1	03247.06
14	Cap	1	10196.00
15	8-1.25mm Jam Nut	1	01256.02
16	Bushing	1	01235.04
17	Knob with Cone Point	1	01266.02
18	Lower Backstem	1	01748.02
19	Knob with Flat Point	1	03408.01
20	Backrest Assembly	1	03431.14
21	Seat Assembly	1	03259.51

OPTIONAL ACCESSORIES	
Caster with Insert	2061N
Top Footrest Assembly	2081

# CHAIR ADJUSTMENT INSTRUCTIONS

To maximize ergonomic benefits of this chair, it is essential to understand how controls function and how they affect your posture.

## LIFT HEIGHT ADJUSTMENT

Lay chair on its side and loosen base knob (Key No. 6). To increase height of seat, grasp seat and pull away from base. To decrease height of seat, grasp seat and push toward base. Retighten knob. Stand chair back up.

## SEAT HEIGHT ADJUSTMENT

Sit centered in seat. Locate handle (Key No. 11) under seat and pull up. Ease weight up or down until you have reached the height you want, and release lever. The proper height is determined by a combination of: height of work surface, task performed and body size. Chair should be high enough so arms form 90° angle at elbow or slightly greater. This allows better circulation in shoulders and neck area and reduces fatigue in forearms and hands. Feet should be flat on ground or footrest. Maintain a 90° angle at bend of knees. If adjustment range is not enough, try "Lift Height Adjustment" and then repeat "Seat Height Adjustment." Seat is shaped to offer firm support. Waterfall front (sloping front edge of seat) reduces pressure under legs and provides for better circulation behind knees. Seat should always swing freely to help prevent twisting of your spine.

## BACKREST HEIGHT ADJUSTMENT

Loosen knob (Key No. 19) behind backrest. Adjust backrest until curve fits into small of your back. This will reduce pressure on the spinal discs, especially in lumbar area. Retighten knob.

## BACKREST DEPTH ADJUSTMENT

Adjustment knob (Key No. 17) is located under seat just behind pneumatic lift. Loosen knob to slide backrest into position. Allow surface of backrest to help support upper body weight by positioning backrest in curve of your spine. This will reduce pressure on the spinal discs, especially in lumbar area. Backrest should tilt freely to enable support in various positions. Tighten knob.

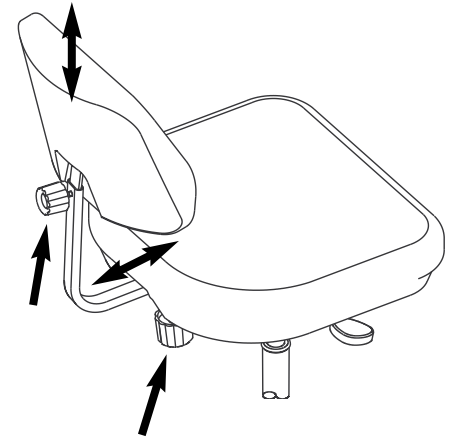
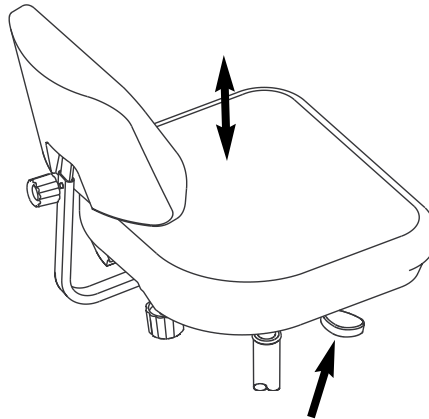
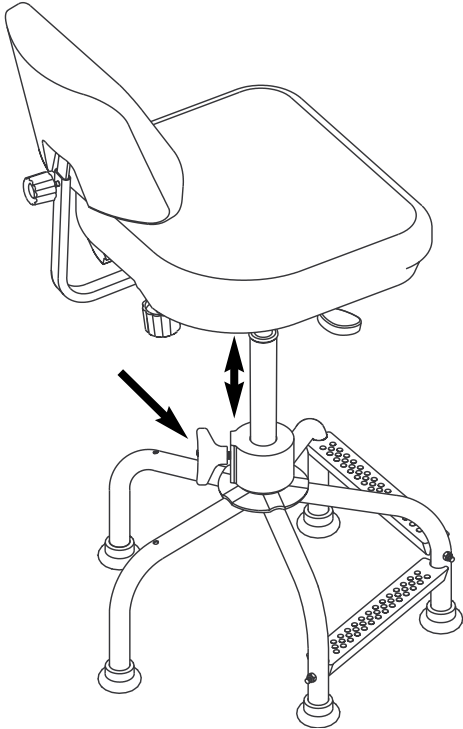

## WARRANTY

Lyon Workspace Products warrants all of its products to be free from manufacturing defects for the life of the product when it is used in accordance with manufacturer's specifications and/or operating instructions. The life of the product is ten years of single shift users, five years for two shift users, and two-and-a-half years for three shift users, for users not weighing more than 250 pounds.

During this period Lyon Workspace Products will repair or replace, at its option, any part found upon examination to be defective. Freight, labor or service charges for removal of defective parts and installation of replacement parts are not included. **All parts that are replaced due to wear, misuse or abuse are not covered by the warranty but replacement parts can be purchased from Lyon Workspace Products.**

This warranty applies to the original purchaser, and the purchaser's sole remedy under this warranty is limited to replacement or repair of the product and specifically excludes consequential, incidental or any other damages directly or indirectly resulting from a failure or loss of use of or by Lyon Workspace Products.

To obtain warranty service, a return authorization by Lyon Workspace Products must accompany all returned merchandise.

Contact your Lyon Dealer or Lyon Workspace Products, P.O. Box 671, Aurora, IL 60507, 800/323-0082 or 630/892-8941.