

BILL OF MATERIALS		
QTY	DESCRIPTION	XX9335
1	INTER LALLY COL & SHIMS	XX9227
1	OUTER AISLE SUPPORT	XX9234
1	108" AISLE EXT COMP	XX9281

SHEET 1 OF 2

**MISSING PARTS OR IN NEED
OF
ASSEMBLY ASSISTANCE?**

Contact us direct for fast friendly service (800) 433-8488
 Int'l calls (630) 892-8941 | WEB: WWW.LYONWORKSPACE.COM | Fax (800) 367-6681

ASSEMBLY INSTRUCTIONS
 FOR 8000 SERIES TWO
 LEVEL SHELVING

LYON LYON WORKSPACE PRODUCTS
 P.O. BOX 671
 800 8001 AURORA, IL 60507

**9335 PAPALLEL
 OUTER AISLE**

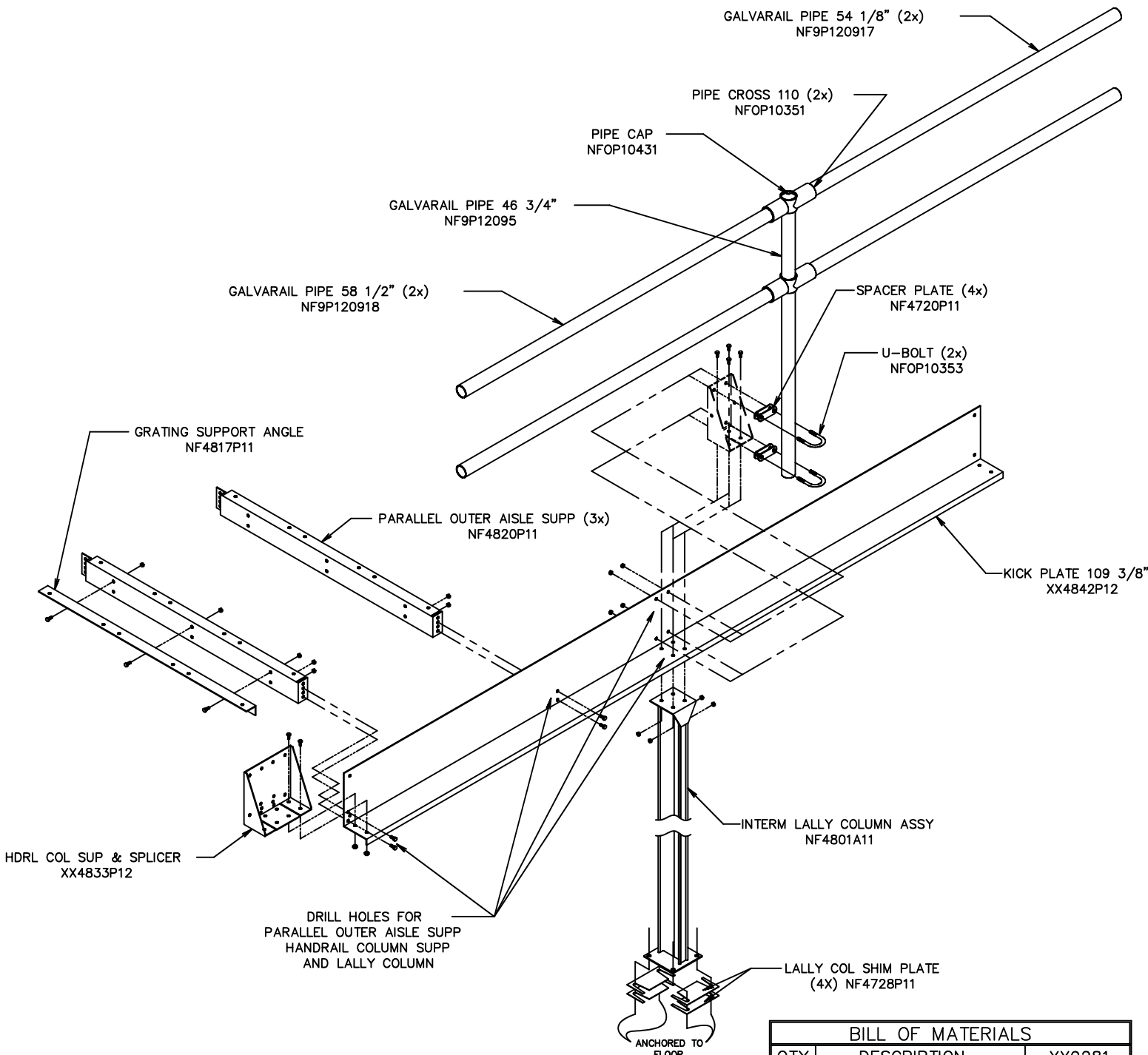

HDRL COL SUP & SPLICER
XX4833P12

DRILL HOLES FOR
PARALLEL OUTER AISLE SUPP
HANDRAIL COLUMN SUPP
AND LALLY COLUMN

BILL OF MATERIALS		
QTY	DESCRIPTION	XX9227
4	LALLY COL BASE SHIM PLATE	NF7428P11
1	INTERM LALLY COLUMN ASSY	NF4801A11

BILL OF MATERIALS		
QTY	DESCRIPTION	XX9234
1	GRATING SUPPORT ANGLE	NF4817P11
3	PARALLEL OUTER AISLE SUPP	NF4820P11

BILL OF MATERIALS		
QTY	DESCRIPTION	XX9281
1	HDRL COL SUP & SPLICER	XX4833P12
1	KICK PLATE 109 3/8"	XX4842P12
2	GALVARAIL PIPE 54 1/8"	NF9P120917
2	GALVARAIL PIPE 58 1/2"	NF9P120918
1	GALVARAIL PIPE 46 3/4"	NF9P12095
2	5/16-18 X 2 3/8 "U" BOLT	NFOP10353
1	PIPE CAP	NFOP10431
4	SPACER PLATE	NF4720P11
2	PIPE CROSS 110	NFOP10351

SHEET 2 OF 2

**MISSING PARTS OR IN NEED
OF
ASSEMBLY ASSISTANCE?**

Contact us direct for fast friendly service (800) 433-8488
Int'l calls (630) 892-8941 | WEB: WWW.LYONWORKSPACE.COM | Fax (800) 367-6681

ASSEMBLY INSTRUCTIONS
FOR 8000 SERIES TWO
LEVEL SHELVING



9335
PARALLEL OUTER AISLE