

DRAWER LABEL ASSEMBLY

LABEL CONTENTS OF DRAWER ON CARDBOARD LABEL. PLACE A LABEL PROTECTOR OVER THE CARDBOARD LABEL, AND INSERT BOTH INTO SLOT OF RIGHT HAND END CAP AS SHOWN. LABEL AND PROTECTOR WILL "DROP" INTO PLACE WHEN FULLY INSERTED.

TO REMOVE, PUSH LABEL AND PROTECTOR UP SLIGHTLY BEFORE SLIDING TO THE RIGHT. IF INSTALLING ON SLIMLINE CABINET, CUT LABEL AND PROTECTOR TO A LENGTH OF 13-3/8" BEFORE INSERTING INTO DRAWER HANDLE.

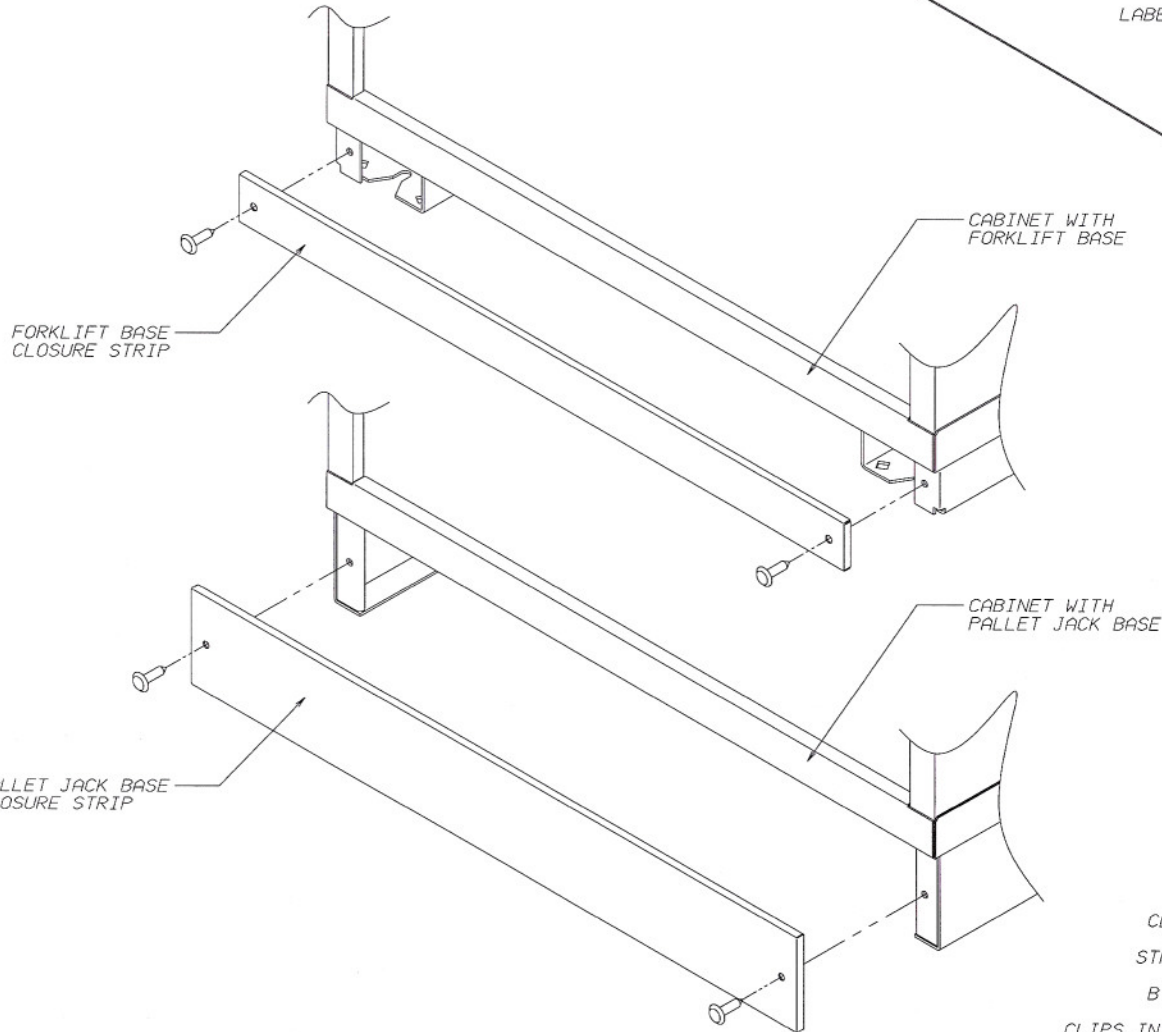
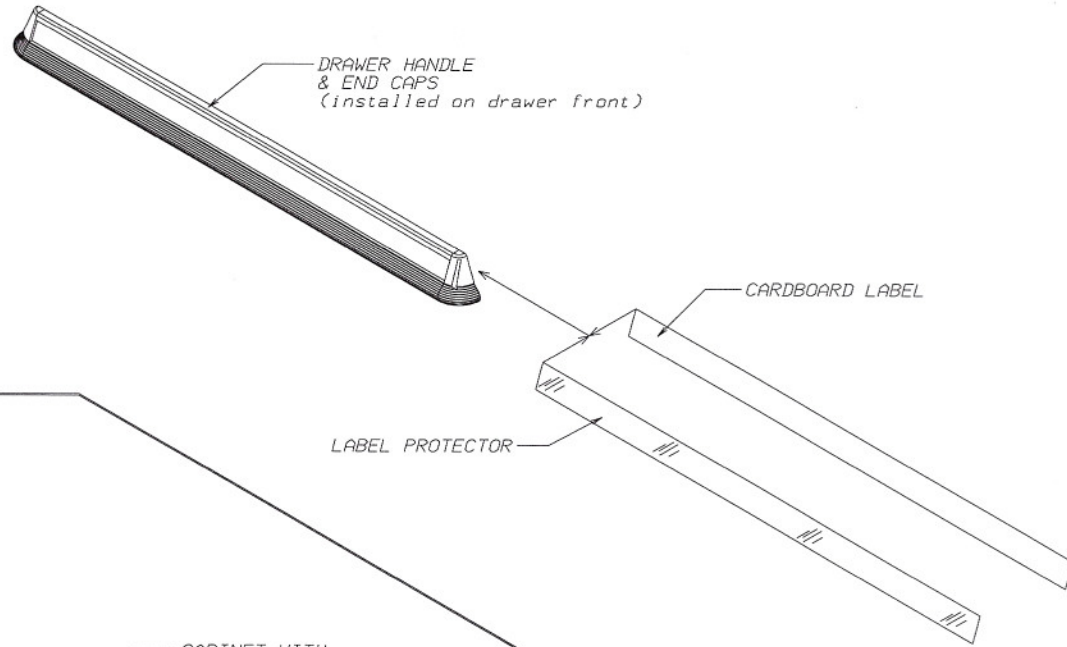

CLOSURE ASSEMBLY

PRESS TWO (2) BLACK TREE CLIPS INTO HOLES ON CLOSURE STRIP. ATTACH THIS ASSEMBLY BY PRESSING END OF THE TREE CLIPS INTO HOLES ON BASE CHANNELS.

REL FOR PRODUCTION	08-15-01	RE
SYM	REVISION	ECN DATE BY
NOTES:		
1) ALL DIMENSIONS ARE INCHES		
MATERIAL		

RAW P/N	WEIGHT (LB)	FINISH:
---	---	---
DATE	DRAWN BY	CHECKED BY
08-15-07	RE	DV
LYON LYON METAL PRODUCTS		
PO BOX 671 AURORA, IL 60507		
(800) 323-0082 FAX: (800) 367-6681		
MDCII	DESCRIPTION	
	CLOSURE STRIP/DRAW LABEL INSTALL	
SHEET	DWG NUMBER	REV
	SS1324	1

NOTICE: THIS IS A CONFIDENTIAL DISCLOSURE LOANED BY SST FOR REFERENCE PURPOSES ONLY