

CABINET DRILL PATTERN  
(RIGHT SIDE SHOWN)

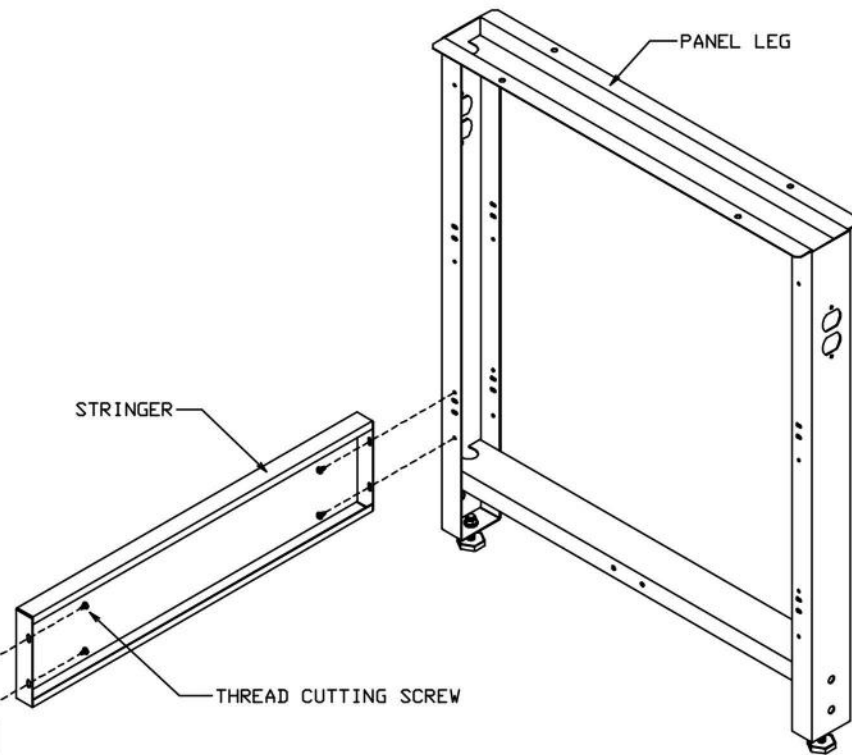
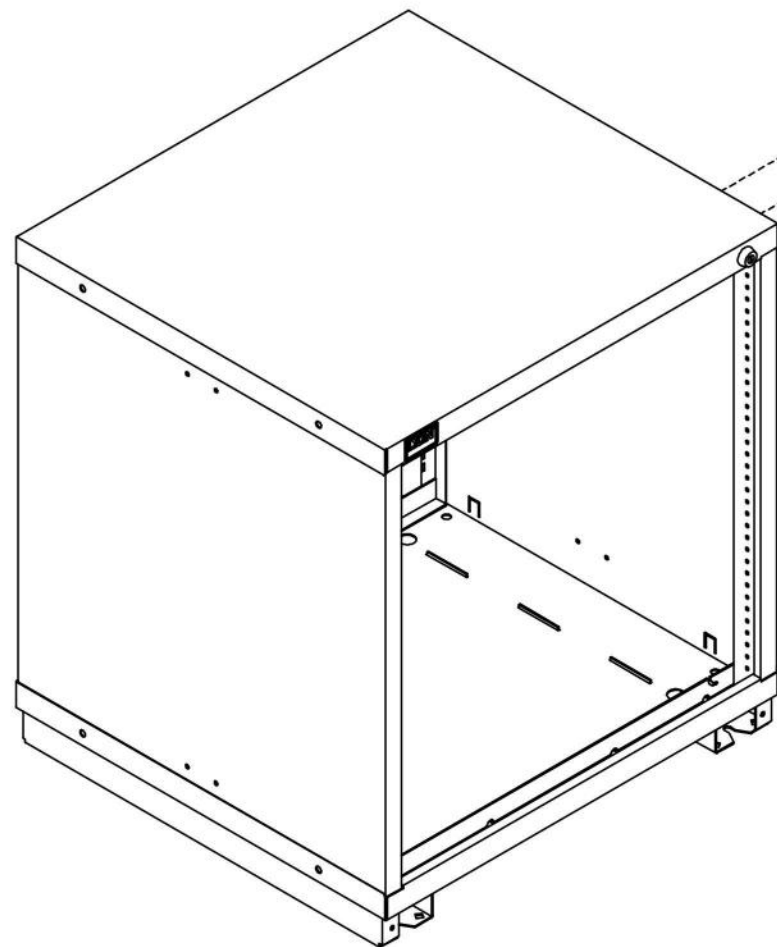

**ASSEMBLY INSTRUCTIONS**

DRILL TWO (2) 0.166 DIAMETER HOLES ON THE SIDE OF THE CABINET WHICH IS TO ACCEPT ATTACHMENT OF THE STRINGER PER DRILL PATTERN SHOWN ABOVE.

ATTACH STRINGER TO CABINET AND PANEL LEG AS SHOWN WITH SUPPLIED #10-24 THREAD CUTTING SCREWS. FOUR (4) SCREWS WILL BE REQUIRED FOR ALL CABINETS.

#10-24 THREAD CUTTING SCREW

SUPPLIED HARDWARE

			P.O. Box 671 AURORA, IL 60507-0671 PHONE: 630-892-8941 FAX: 800-367-6681		
			NOTICE: THIS IS A CONFIDENTIAL DISCLOSURE LOANED BY LYON WORKSPACE FOR REFERENCE PURPOSES ONLY		
DATE	DRAWN BY	CHECKED BY	DESCRIPTION		
07-19-12	JR	DWV	INSTALLATION STRINGER MDC		
SHEET	DRAWING NUMBER		REV		
1	SS1873		1		