

DETAIL "A"

VERTICAL SECTION THROUGH SHELVING AND DOORS SHOWING ATTACHMENT OF LOCK CLIP TO TOP AND BOTTOM SHELVES, HINGES TO SHELVING UPRIGHTS AND DOORS TO HINGES.

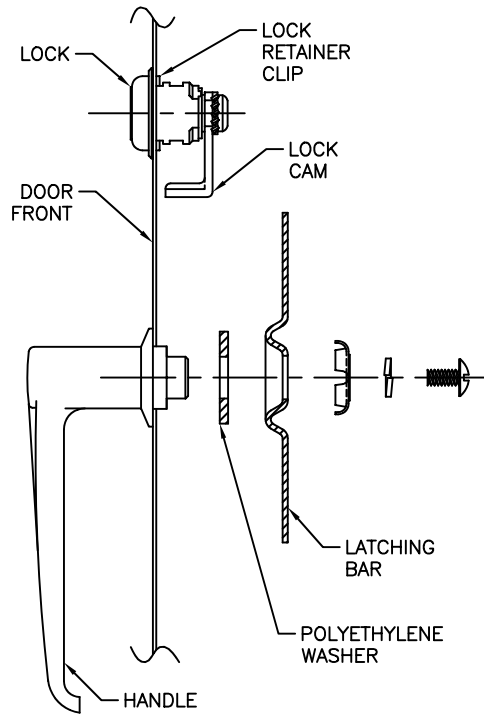

DETAIL "C"

SECTION THROUGH DOOR SHOWING HANDLE & LOCK ATTACHMENT

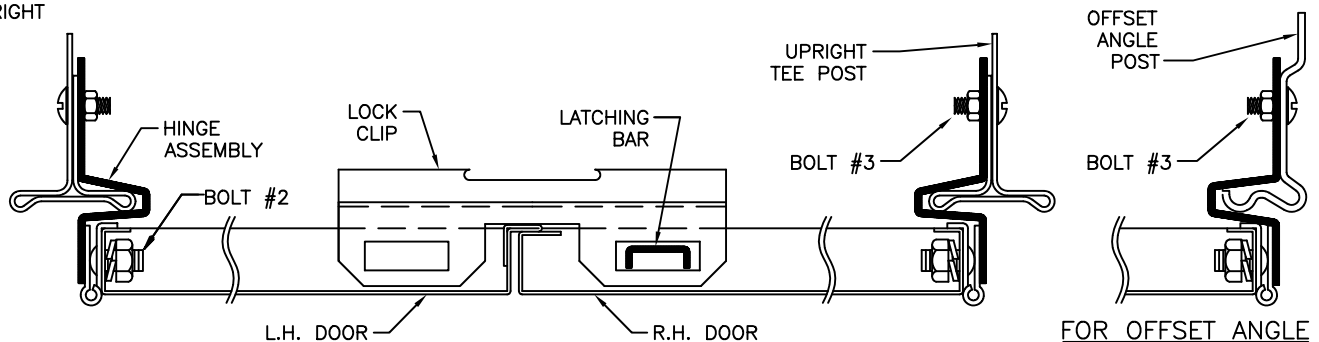

DETAIL "B"

PLAN SECTION THROUGH DOORS SHOWING ATTACHMENT TO UPRIGHTS.

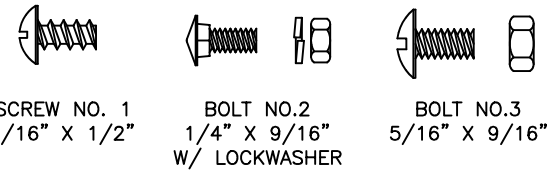
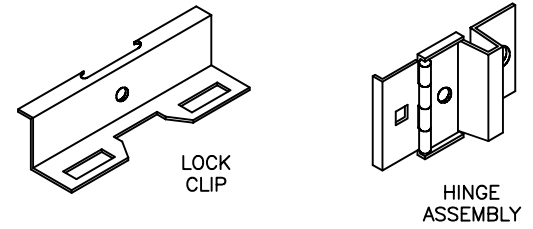

ASSEMBLY OPERATIONS

- 1.) ATTACH A LOCK CLIP TO THE TOP AND BOTTOM SHELF FLANGE WITH A NO.1 SCREW. (SEE DETAILS "A" & "B")
- 2.) BOLT THREE HINGES TO EACH DOOR USING NO.2 BOLTS WITH A LOCKWASHER UNDER EACH NUT. DRAW THE NUTS UP TIGHT. (SEE DETAILS "A" & "B")
- 3.) BOLT THE HINGES TO THE UPRIGHT TEE POST USING NO.3 BOLTS. DRAW THE NUTS UP TIGHT. (SEE DETAILS "A" & "B")
- 4.) INSTALL HANDLE AND LATCHING BAR. (SEE DETAIL "C")
- 5.) ATTACH THE LOCK. (SEE DETAIL "C")

IMPORTANT NOTE:

MAKE SURE SHELVING RACK IS LEVEL BEFORE INSTALLING THE DOORS. UPRIGHTS MUST BE PLUMB FOR THE DOORS TO OPERATE CORRECTLY.

ASSEMBLY INSTRUCTIONS FOR NO. 8837 DOUBLE SWINGING DOORS

| | |
|--------------------|--------------|
| DRAWN BY: LAR | DATE: 2-3-92 |
| REVISED | DATE |
| ADDED NOTE | 2-5-92 |
| ADDED OFFSET ANGLE | 8-24-92 |
| E-010601-1 | 6-1-01 |

4782-DA