

GENERAL INSTRUCTIONS

PARTS IDENTIFICATION:

- BEFORE INSTALLING MODULAR DRAWER UNITS, IT MUST BE VERIFIED THAT THE UPRIGHTS ARE PLUMB AND THE SHELVES ARE LEVEL. THE SHELVING UNIT MUST ALSO BE PROPERLY ANCHORED AS DESCRIBED IN THE INSTALLATION SHEET PROVIDED WITH THE SHELVING UNIT. IF NEEDED, CONTACT REPUBLIC CUSTOMER SERVICE FOR PROPER ANCHORING METHODS. DRAWERS WILL NOT OPERATE CORRECTLY IF THE ABOVE CRITERIA IS NOT MET.
- EACH UNIT MUST HAVE A SHELF ABOVE AND BELOW THE UNIT. TWO UNITS IN ONE SHELVING SECTION MUST BE SEPARATED BY A SHELF. THE SHELF SPACING FOR EACH UNIT IS 1 1/2" GREATER THAN NOMINAL. EXAMPLE: ONE 24" UNIT (30 SEGMENTS) REQUIRES A SPACE OF 25 1/2". THIS SPACE IS MEASURED FROM TOP OF SHELF TO TOP OF SHELF.
- MODULAR DRAWERS ARE AVAILABLE IN THE FOLLOWING SIZES:

FRONT HEIGHT	USABLE HEIGHT	SEGMENTS
3 1/16"	2 1/4"	4
3 7/8"	3"	5
4 5/16"	3 7/8"	6
5 7/16"	4 5/8"	7
6 3/16"	5 3/8"	8
7"	6 1/4"	9
7 3/4"	7"	10
8 9/16"	7 3/4"	11
9 3/8"	8 1/2"	12
10 1/4"	9 3/8"	13
10 7/8"	10 1/8"	14
11 3/4"	10 7/8"	15
12 1/2"	11 3/4"	16
13 5/16"	12 1/2"	17
14 1/16"	13 1/4"	18

ANY COMBINATION OF DRAWER SEGMENTS TOTALING 15 FOR THE 12" UNIT, 22 FOR THE 18" UNIT, 30 FOR THE 24" UNIT OR 45 FOR THE 36" UNIT MAY BE USED

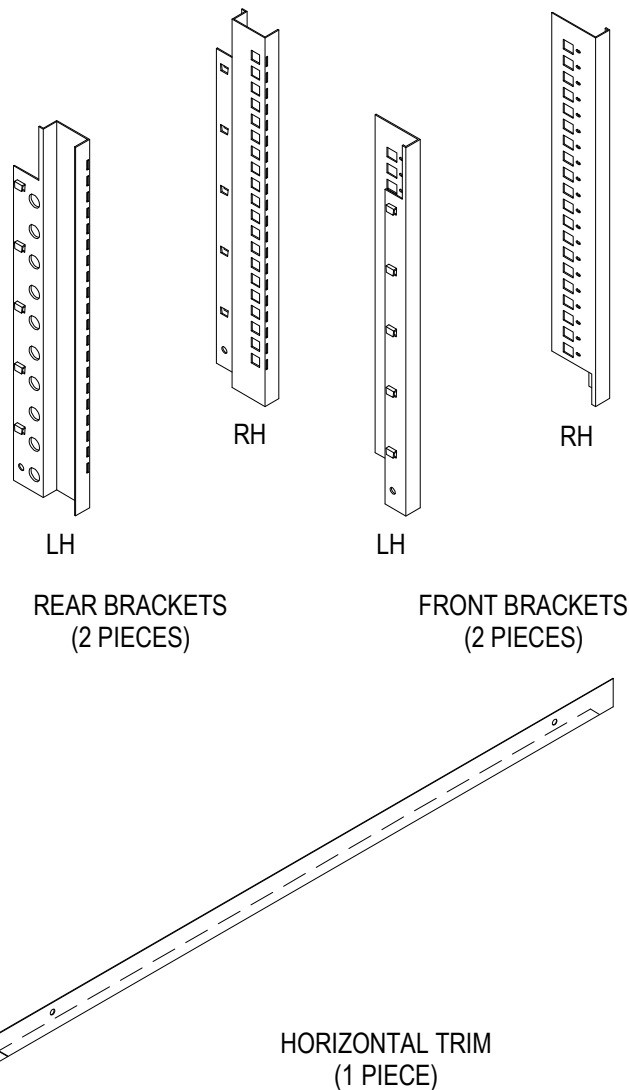

SUPPLIED FASTENERS: SHOWN ACTUAL SIZE

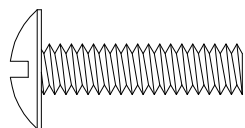

1/4"-20 X 1"
SLOTTED HEAD SCREW
(4 PIECES)

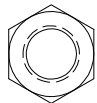

1/4"-20 HEX NUT
(4 PIECES)

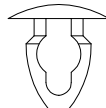

PANEL CLIP
(2 PIECES)



#8-32 x 3/8"
FLAT HEAD TAPPING SCREW
(2 PIECES PER DRAWER)

SHEET 1

**IN NEED OF
ASSEMBLY ASSISTANCE?**

Contact us direct for fast friendly service (800) 477-1255

www.republicstorage.com

ASSEMBLY INSTRUCTIONS
FOR 36" WIDE MODULAR
DRAWERS IN SHELVING

Republic
STORAGE PRODUCTS, LLC

3743 BOETTLER OAKS DR.
SUITE A
UNIONTOWN, OH 44685

9117-CA

ASSEMBLY OPERATION #1

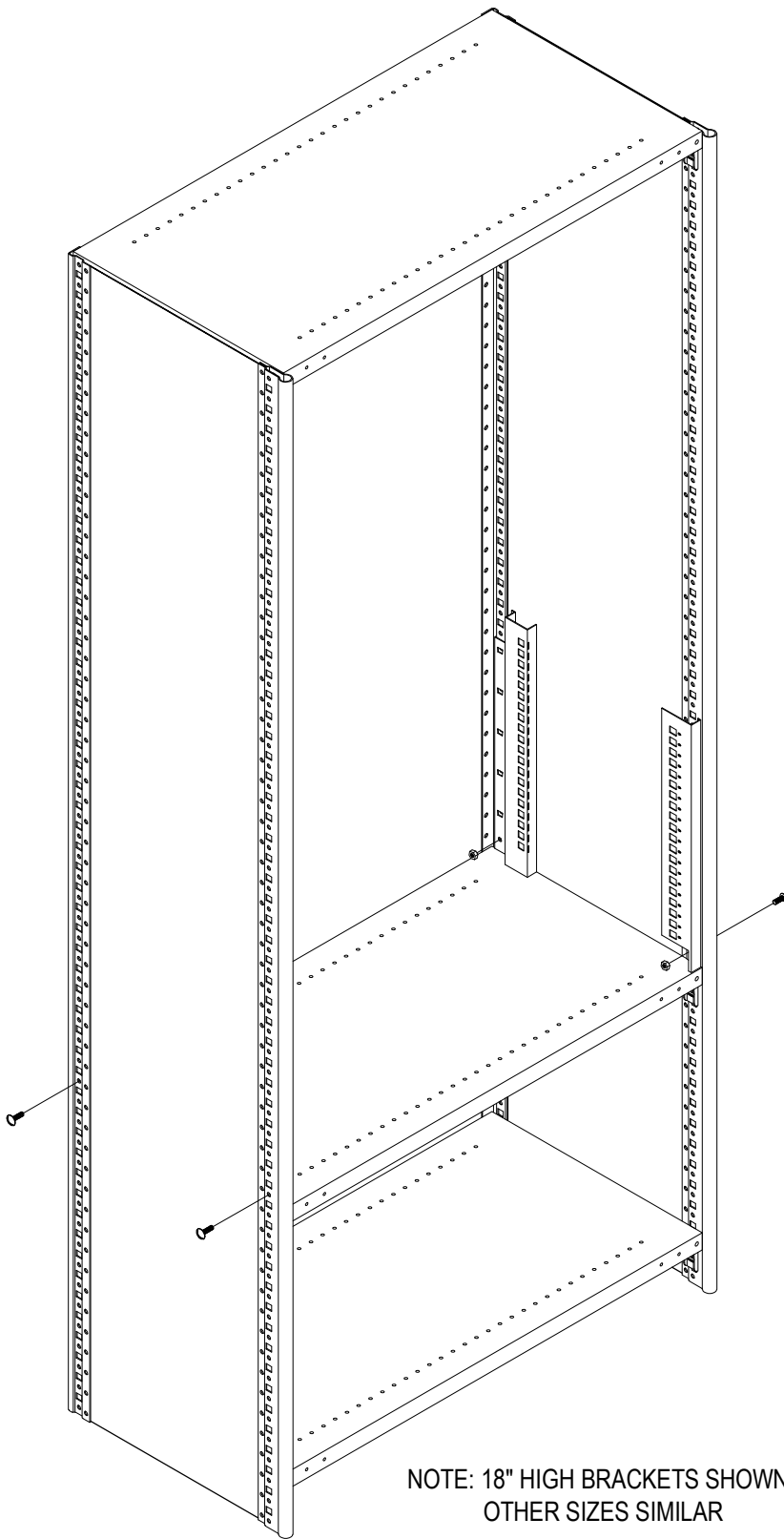

NOTE: 18" HIGH BRACKETS SHOWN
OTHER SIZES SIMILAR

- 1.) DETERMINE DESIRED SHELF SPACING WITHIN SHELVING SECTION. ASSEMBLE SHELVING AS DESCRIBED IN THE INSTALLATION SHEET PROVIDED WITH THE SHELVING UNIT, OMITTING THE SHELF DIRECTLY ABOVE THE MODULAR DRAWER UNIT. ONE 12" UNIT REQUIRES A SPACE OF 13 1/2", ONE 18" UNIT REQUIRES A SPACE OF 19 1/2", ONE 24" UNIT REQUIRES A SPACE OF 25 1/2", AND ONE 36" UNIT REQUIRES A SPACE OF 37 1/2". THIS SPACE IS MEASURED FROM TOP OF SHELF TO TOP OF SHELF.
- 2.) ATTACH THE FRONT AND REAR BRACKETS BY ALIGNING THE TANGS TO THE SQUARE HOLES IN THE POSTS AND PRESSING DOWN. SECURE BRACKETS IN PLACE WITH (1) 1/4"-20x1 BOLT AND NUT AT THE BOTTOM OF EACH BRACKET. WHEN ASSEMBLING A ROW OF SHELVING WITH MATCHING MODULAR DRAWER UNITS, THE SAME BOLT CAN BE USED TO ATTACH ADJACENT MOUNTING BRACKETS TO AN INTERMEDIATE SHELVING UPRIGHT.

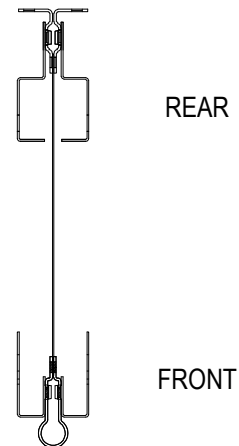

REQUIRED HARDWARE:

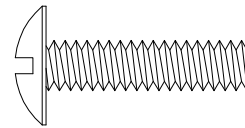

1/4"-20 X 1"
SLOTTED HEAD SCREW
(4 PIECES)

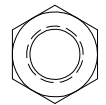

1/4"-20 HEX NUT
(4 PIECES)

SHEET 2

**IN NEED OF
ASSEMBLY ASSISTANCE?**

Contact us direct for fast friendly service (800) 477-1255

www.republicstorage.com

ASSEMBLY INSTRUCTIONS
FOR 36" WIDE MODULAR
DRAWERS IN SHELVING

Republic
STORAGE PRODUCTS, LLC

3743 BOETTLER OAKS DR.
SUITE A
UNIONTOWN, OH 44685

9117-CA

ASSEMBLY OPERATION #2

1.) BEGINNING AT THE BOTTOM OF THE MOUNTING BRACKETS, ATTACH THE STATIONARY PORTION OF THE DRAWER SLIDE BY ALIGNING THE SLIDE'S REAR TAB INTO THE LOWEST SQUARE HOLE IN THE REAR MOUNTING BRACKET. THEN, ALIGN THE FRONT TAB TO THE SQUARE HOLE IN THE FRONT MOUNTING BRACKET AND PRESS DOWN. WHEN THE SLIDE IS SEATED, THE #8 SCREW SHOULD BE INSERTED TO SECURE THE SLIDE IN PLACE. (SEE DETAILS AT RIGHT)

2.) PROCEED WITH INSTALLING THE MIDDLE SECTION OF THE DRAWER SLIDES. PAY ATTENTION TO RIGHT HAND AND LEFT HAND WHEN ASSEMBLING. AFTER THE MIDDLE SECTIONS OF THE SLIDES ARE INSERTED, MAKE SURE THE SAFETY CATCHES ARE UNLOCKED BEFORE ATTEMPTING TO INSERT A DRAWER.

STATIONARY SECTION OF SLIDE

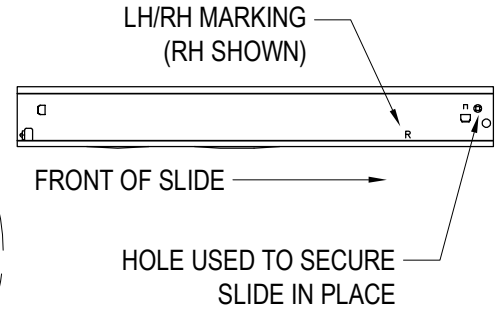

MIDDLE SECTION OF SLIDE

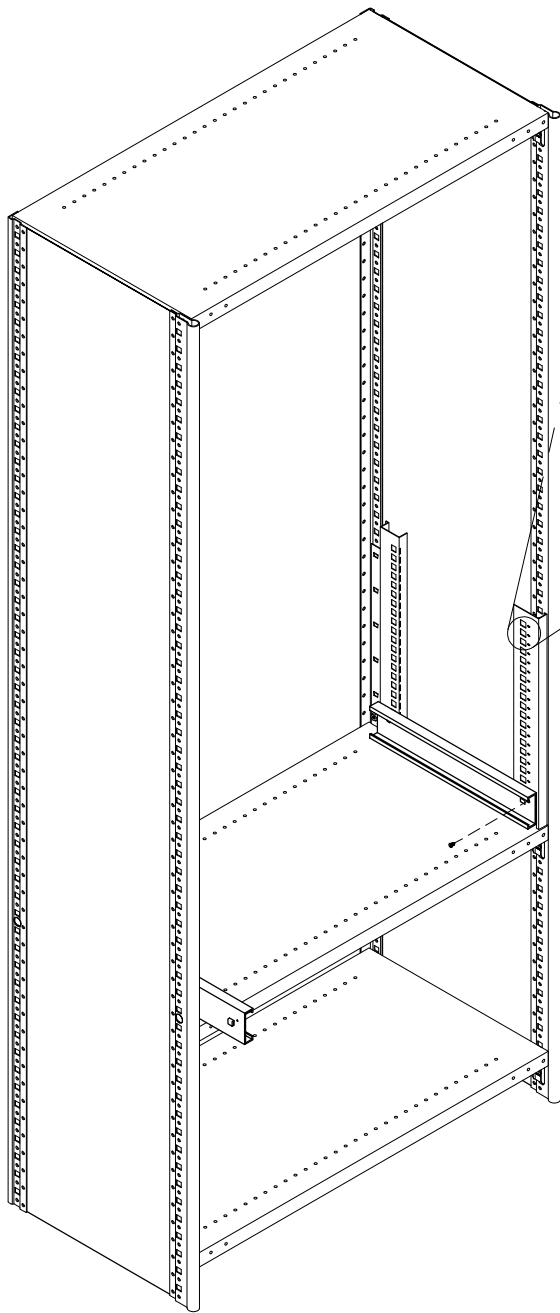
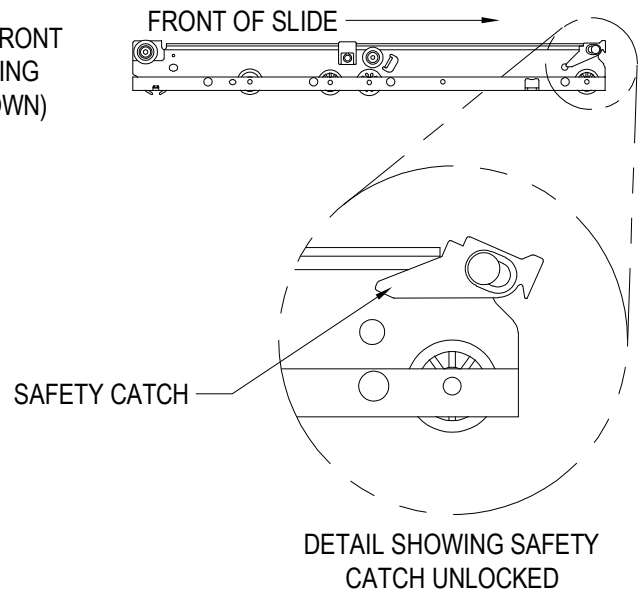

24" DEEP LOCATION

18" DEEP LOCATION

DETAIL SHOWING FRONT BRACKET PUNCHING (RIGHT HAND SHOWN)

REQUIRED HARDWARE:



#8-32 x 3/8"
FLAT HEAD TAPPING SCREW
(2 PER DRAWER) SUPPLIED WITH DRAWER

NOTE: DRAWER SLIDES ARE SUPPLIED WITH THE INDIVIDUAL DRAWERS

SHEET 3

**IN NEED OF
ASSEMBLY ASSISTANCE?**

Contact us direct for fast friendly service (800) 477-1255

www.republicstorage.com

ASSEMBLY INSTRUCTIONS
FOR 36" WIDE MODULAR
DRAWERS IN SHELIVING

Republic
STORAGE PRODUCTS, LLC

3743 BOETTNER OAKS DR.
SUITE A
UNIONTOWN, OH 44685

9117-CA

ASSEMBLY OPERATION #3

- 1.) INSERT DRAWER INTO DRAWER SLIDES. THE DRAWER WILL NEED TO BE LIFTED OVER THE DRAWER STOPS DURING THIS PROCESS. AFTER THE DRAWER IS FULLY INSTALLED, ENSURE THE SAFETY CATCHES ARE LOCKED ON THE FRONT OF EACH SLIDE. THIS PREVENTS THE DRAWER FROM SLIPPING OVER THE DRAWER STOPS.
- 2.) CONTINUE TO INSTALL DRAWER SLIDES FOR THE REMAINING DRAWERS. THE SPACING IS DETERMINED BY THE HEIGHT OF THE DRAWER FRONT BELOW. THE NEXT DRAWER SLIDE SHOULD BE JUST ABOVE THE DRAWER FRONT BELOW.

** REFER TO ASSEMBLY OPERATION #2 FOR MORE DETAILED INSTRUCTIONS ON DRAWER SLIDE INSTALLATION

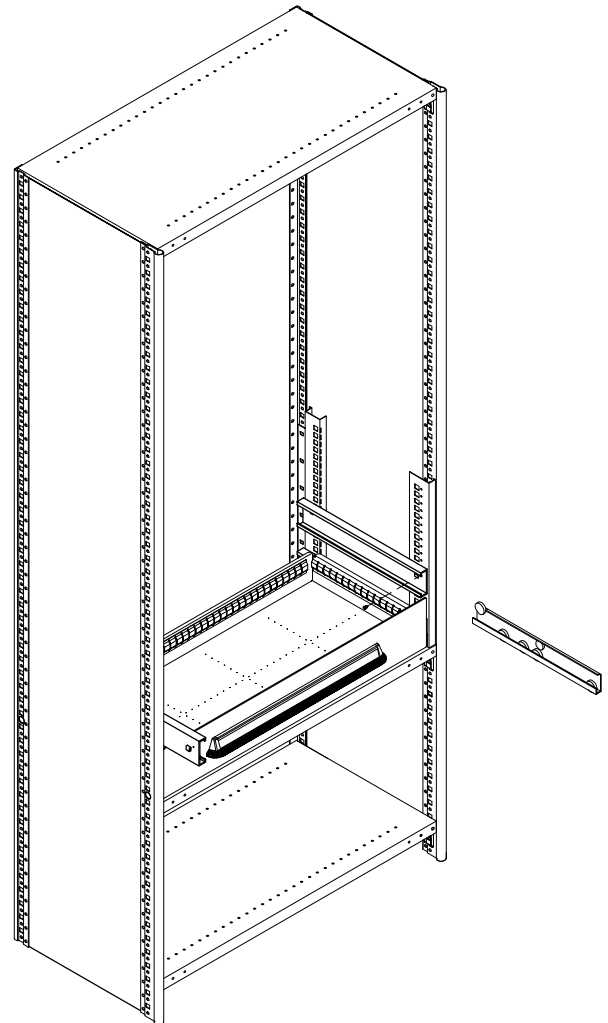
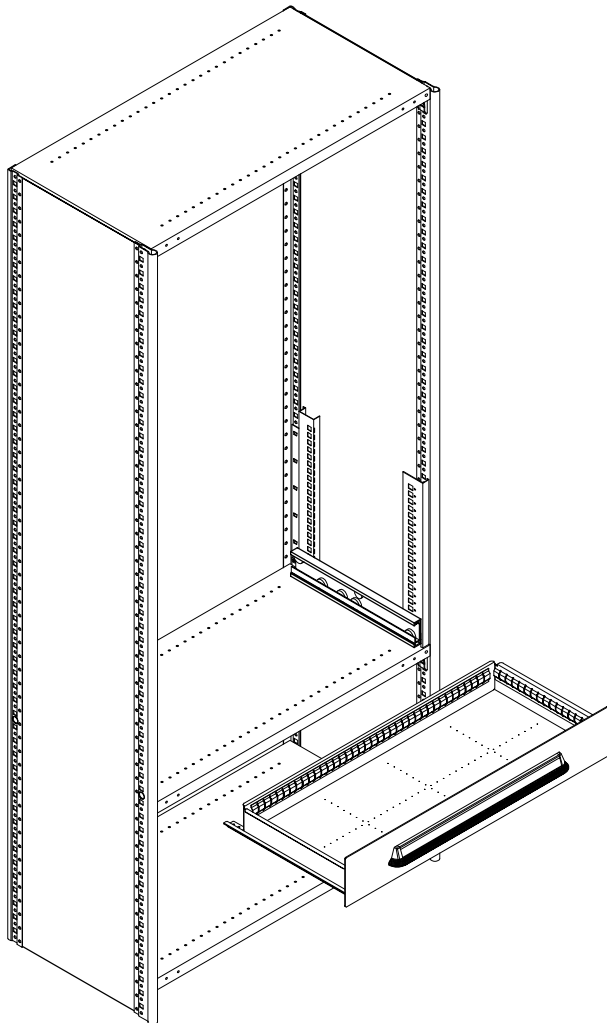

REQUIRED HARDWARE:



#8-32 x 3/8"
FLAT HEAD TAPPING SCREW
(2 PER DRAWER) SUPPLIED WITH DRAWER

SHEET 4

**IN NEED OF
ASSEMBLY ASSISTANCE?**

Contact us direct for fast friendly service (800) 477-1255

www.republicstorage.com

ASSEMBLY INSTRUCTIONS
FOR 36" WIDE MODULAR
DRAWERS IN SHELVEING

Republic
STORAGE PRODUCTS, LLC

3743 BOETTLER OAKS DR.
SUITE A
UNIONTOWN, OH 44685

9117-CA

ASSEMBLY OPERATION #4

- 1.) INSTALL SHELF DIRECTLY ABOVE MODULAR DRAWER UNIT, AND INSTALL ANY OTHER DESIRED SHELVES AT THIS TIME.
- 2.) ATTACH HORIZONTAL TRIM PIECE TO FACE OF SHELF WITH (2) PANEL CLIPS.

IF DRAWER PARTITIONS AND DIVIDERS WERE ORDERED, THEY CAN BE INSTALLED AT THIS TIME.

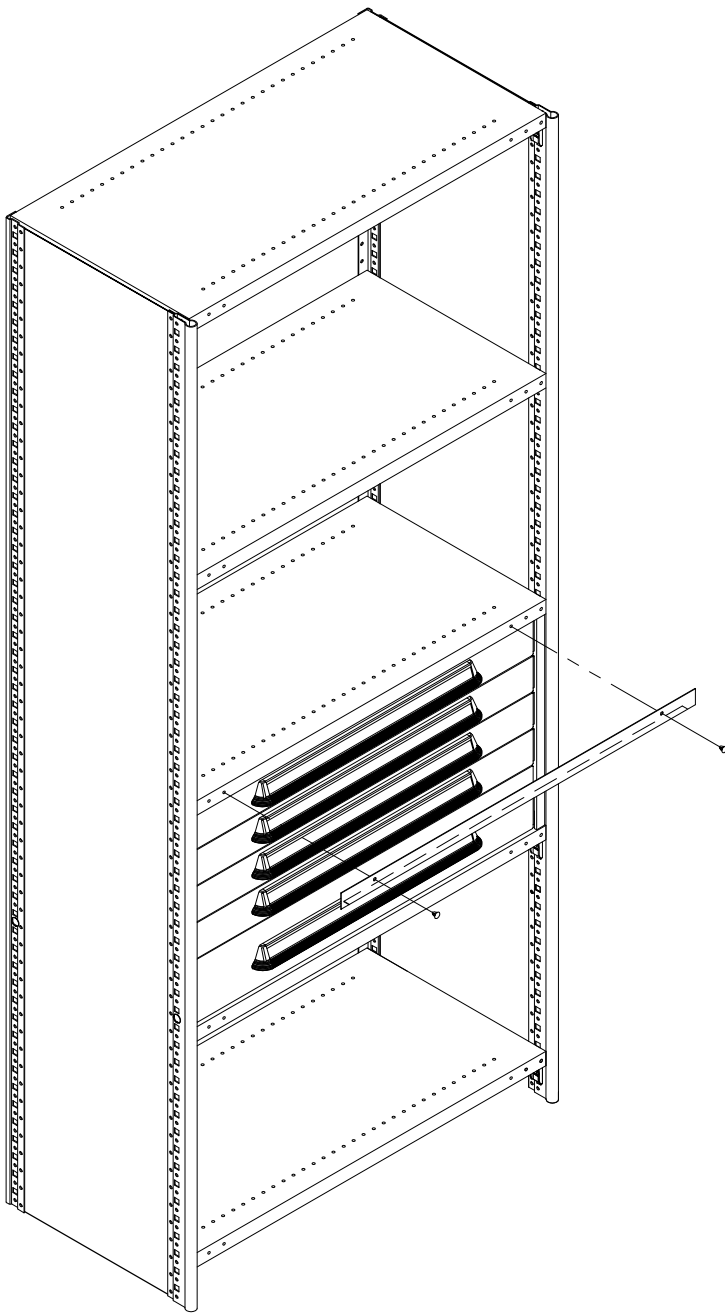

REQUIRED HARDWARE:

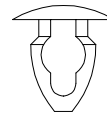

PANEL CLIP
(2 PIECES)

SHEET 5

IN NEED OF ASSEMBLY ASSISTANCE?

Contact us direct for fast friendly service (800) 477-1255

www.republicstorage.com

ASSEMBLY INSTRUCTIONS
FOR 36" WIDE MODULAR
DRAWERS IN SHELVING

Republic
STORAGE PRODUCTS, LLC

3743 BOETTLER OAKS DR.
SUITE A
UNIONTOWN, OH 44685

9117-CA