

PART NUMBER OPTIONS;

N27303010020L = LOCKABLE SWING DOOR

N27303010020N = NO LOCKING SYSTEM

FEATURES;

BASE SHELF AND ADJUSTABLE SHELF BEHIND LOCKABLE SWING DOOR

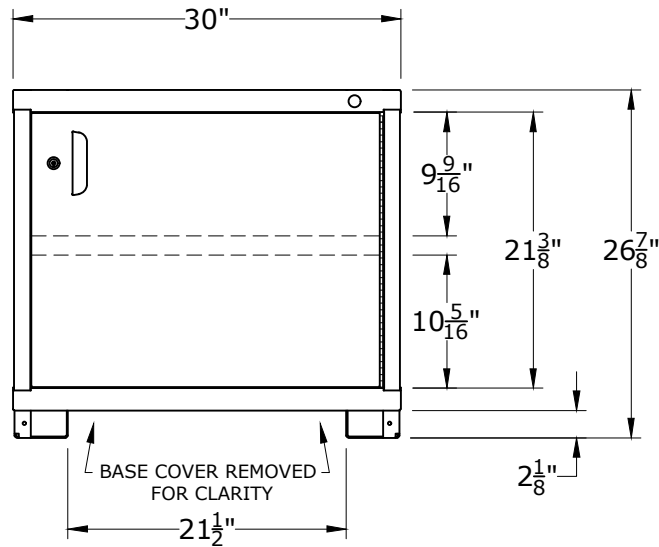

CABINET DEPTH @ 28-1/4"
w/ 400lb. CAPACITY SHELVES
EACH @ 28-1/2"W x 25"D USABLE

LYON P.O. Box 671
AURORA, IL 60507-0671
PHONE: 800-323-0082
www.lyonworkspace.com

NOTICE: THIS DOCUMENT IS CONFIDENTIAL AND PROPRIETARY. NO PART OF THIS DOCUMENT MAY BE DISCLOSED TO A THIRD PARTY WITHOUT THE PRIOR WRITTEN CONSENT OF LYON LLC

DATE 06/29/17	DRAWN BY JR	CHECKED BY DWV
------------------	----------------	-------------------

DESCRIPTION

PRE-ENGINEERED
SHELF CABINET
DESK - STANDARD

SHEET 1	DRAWING NUMBER 2730301002	REV 1
------------	------------------------------	----------