

PART NUMBER OPTIONS;

N31303010070L = LOCKABLE SWING DOOR
N31303010070N = NO LOCKING SYSTEM

FEATURES;

BASE SHELF AND ADJUSTABLE SHELF BEHIND LOCKABLE SWING DOOR

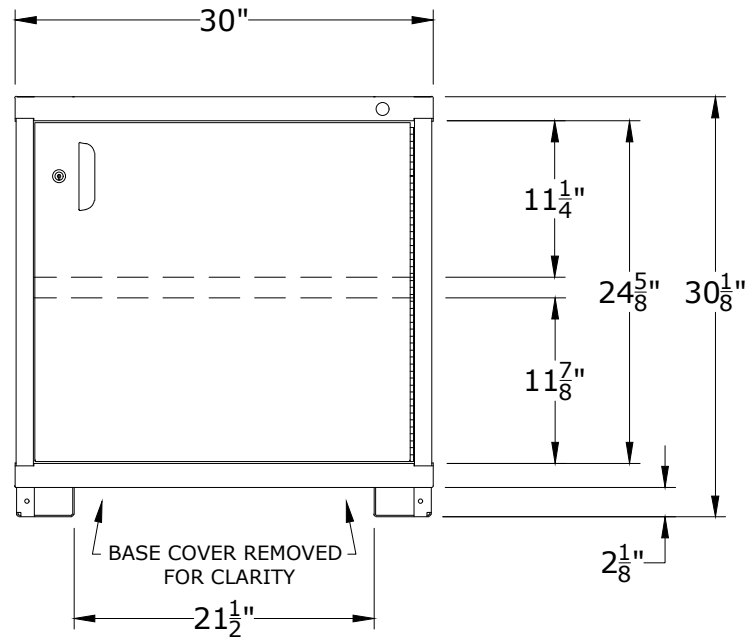

CABINET DEPTH @ 28-1/4" w/
400Lb. CAPACITY SHELVES
EACH @ 28-1/2"W x 25"D USABLE

LYON P.O. Box 671
AURORA, IL 60507-0671
PHONE: 800-323-0082
www.lyonworkspace.com

NOTICE: THIS DOCUMENT IS CONFIDENTIAL AND PROPRIETARY. NO PART OF THIS DOCUMENT MAY BE DISCLOSED TO A THIRD PARTY WITHOUT THE PRIOR WRITTEN CONSENT OF LYON LLC

DATE 07/05/17	DRAWN BY JR	CHECKED BY DWV
------------------	----------------	-------------------

DESCRIPTION

PRE-ENGINEERED
SHELF CABINET
TABLE - STANDARD

SHEET	DRAWING NUMBER 3130301007	REV 1
-------	------------------------------	----------