

PART NUMBER OPTIONS;

N35223010060L = LOCKABLE SWING DOOR

N35223010060N = NO LOCKING SYSTEM

FEATURES;

BASE SHELF AND ADJUSTABLE SHELF BEHIND LOCKABLE SWING DOOR

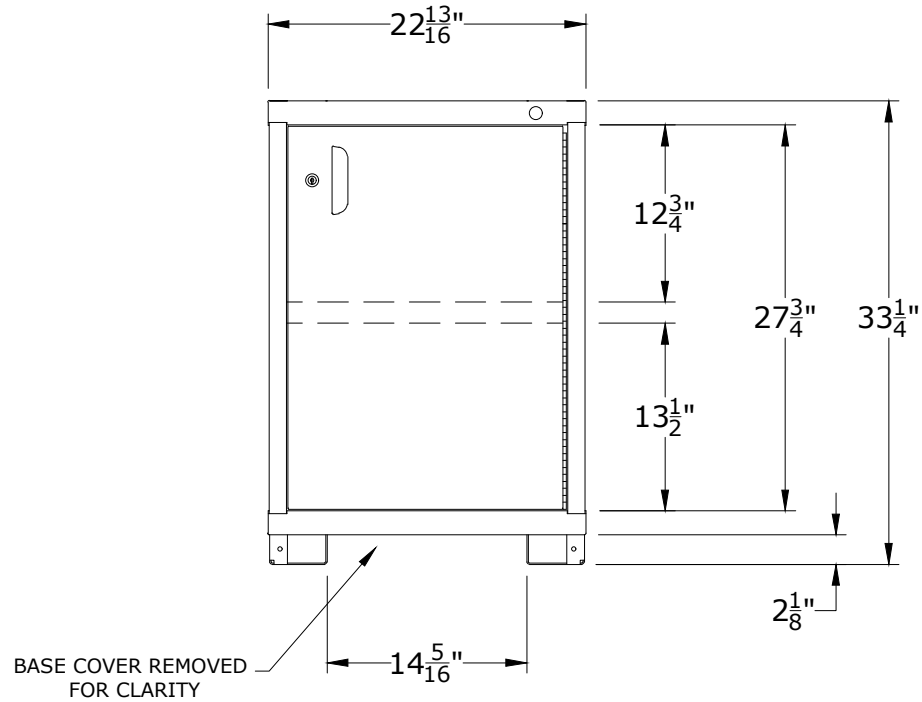

CABINET DEPTH @ $28\frac{1}{4}$ " w/
400lb. CAPACITY SHELVES
EACH @ $22\frac{5}{16}$ "W x 25"D USABLE

LYON P.O. Box 671
AURORA, IL 60507-0671
PHONE: 800-323-0082
www.lyonworkspace.com

NOTICE: THIS DOCUMENT IS CONFIDENTIAL AND PROPRIETARY. NO PART OF THIS DOCUMENT MAY BE DISCLOSED TO A THIRD PARTY WITHOUT THE PRIOR WRITTEN CONSENT OF LYON LLC

DATE 07/05/17	DRAWN BY JR	CHECKED BY DWV
------------------	----------------	-------------------

DESCRIPTION

PRE-ENGINEERED
SHELF CABINET
BENCH - SLENDER

SHEET	DRAWING NUMBER 3522301006	REV 1
-------	------------------------------	----------