

COMPARTMENT SIZE	3	4	5	6	7	8	9	10	11	12	13	14	15	16
DIMENSION (CLEAR)	1 $\frac{7}{8}$ "	2 $\frac{11}{16}$ "	3 $\frac{1}{2}$ "	4 $\frac{1}{4}$ "	5 $\frac{1}{16}$ "	5 $\frac{7}{8}$ "	6 $\frac{11}{16}$ "	7 $\frac{1}{2}$ "	8 $\frac{1}{4}$ "	9 $\frac{1}{16}$ "	9 $\frac{7}{8}$ "	10 $\frac{11}{16}$ "	11 $\frac{1}{2}$ "	12 $\frac{1}{4}$ "

PART NUMBER OPTIONS:

- S273030000A0L** = SINGLE DRAWER ACCESS / NO LAYOUTS
- S273030000A1L** = SINGLE DRAWER ACCESS / LAYOUTS FACTORY INSTALLED
- M273030000A0L** = MULTIPLE DRAWER ACCESS / NO LAYOUTS
- M273030000A1L** = MULTIPLE DRAWER ACCESS / LAYOUTS FACTORY INSTALLED
- N273030000A0N** = NO LOCKING SYSTEM / NO LAYOUTS
- N273030000A1N** = NO LOCKING SYSTEM / LAYOUTS FACTORY INSTALLED

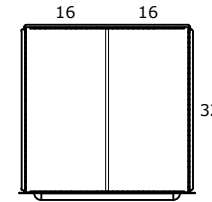

DRAWER LAYOUT "0A"
2 COMPARTMENTS

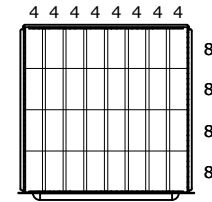

DRAWER LAYOUT "0J"
32 COMPARTMENTS

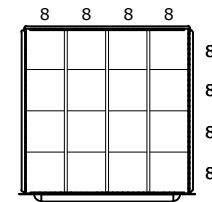

DRAWER LAYOUT "0P"
16 COMPARTMENTS

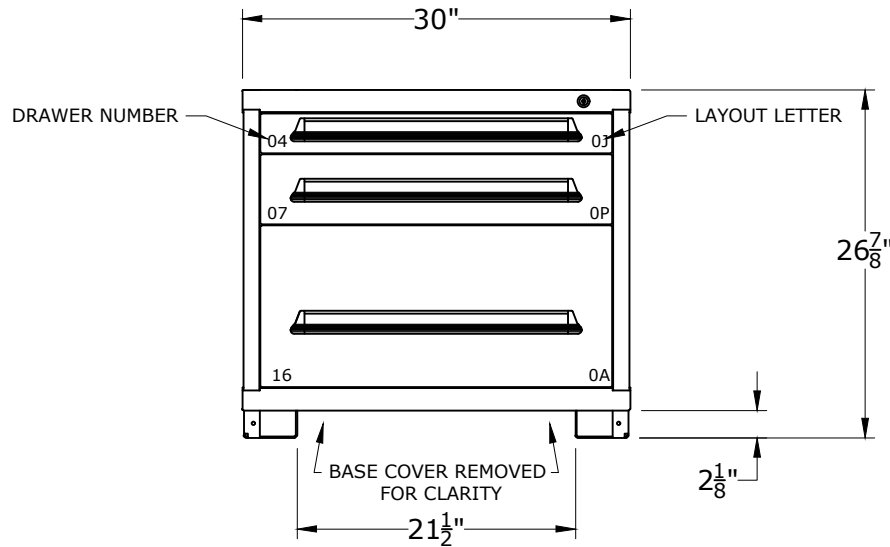

CABINET DEPTH @ 28-1/4" w/
FULL EXTENSION, 450lb. CAPACITY DRAWERS
EACH @ 25-1/8"W x 25-1/8"D USABLE

*OTHER LOCK OPTIONS AVAILABLE, CONTACT FOR DETAILS

DRAWER NUMBER	04	05	06	07	08	09	10	11	12	13	14	15	16	17	18
USABLE HEIGHT	2 $\frac{1}{4}$ "	3"	3 $\frac{7}{8}$ "	4 $\frac{5}{8}$ "	5 $\frac{3}{8}$ "	6 $\frac{1}{4}$ "	7"	7 $\frac{3}{4}$ "	8 $\frac{1}{2}$ "	9 $\frac{3}{8}$ "	10 $\frac{1}{8}$ "	10 $\frac{7}{8}$ "	11 $\frac{3}{4}$ "	12 $\frac{1}{2}$ "	13 $\frac{1}{4}$ "

LYON P.O. Box 671
AURORA, IL 60507-0671
PHONE: 800-323-0082
www.lyonworkspace.com

NOTICE: THIS DOCUMENT IS CONFIDENTIAL AND PROPRIETARY. NO PART OF THIS DOCUMENT MAY BE DISCLOSED TO A THIRD PARTY WITHOUT THE PRIOR WRITTEN CONSENT OF LYON LLC

DATE 06-19-17	DRAWN BY DB	CHECKED BY .
------------------	----------------	-----------------

DESCRIPTION
**PRE-ENGINEERED CABINET
DESK - STANDARD
(3) DRAWERS
(50) COMPARTMENTS**

SHEET 1	DRAWING NUMBER 273030000A	REV 1
------------	-------------------------------------	----------