

COMPARTMENT SIZE	3	4	5	6	7	8	9	10	11	12	13	14	15	16
DIMENSION (CLEAR)	1 $\frac{7}{8}$ "	2 $\frac{11}{16}$ "	3 $\frac{1}{2}$ "	4 $\frac{1}{4}$ "	5 $\frac{1}{16}$ "	5 $\frac{7}{8}$ "	6 $\frac{11}{16}$ "	7 $\frac{1}{2}$ "	8 $\frac{1}{4}$ "	9 $\frac{1}{16}$ "	9 $\frac{7}{8}$ "	10 $\frac{11}{16}$ "	11 $\frac{1}{2}$ "	12 $\frac{1}{4}$ "

PART NUMBER OPTIONS;

- S31303010130L** = SINGLE DRAWER ACCESS / NO LAYOUTS
- S31303010131L** = SINGLE DRAWER ACCESS / LAYOUTS FACTORY INSTALLED
- M31303010130L** = MULTIPLE DRAWER ACCESS / NO LAYOUTS
- M31303010131L** = MULTIPLE DRAWER ACCESS / LAYOUTS FACTORY INSTALLED
- N31303010130N** = NO LOCKING SYSTEM / NO LAYOUTS
- N31303010131N** = NO LOCKING SYSTEM / LAYOUTS FACTORY INSTALLED

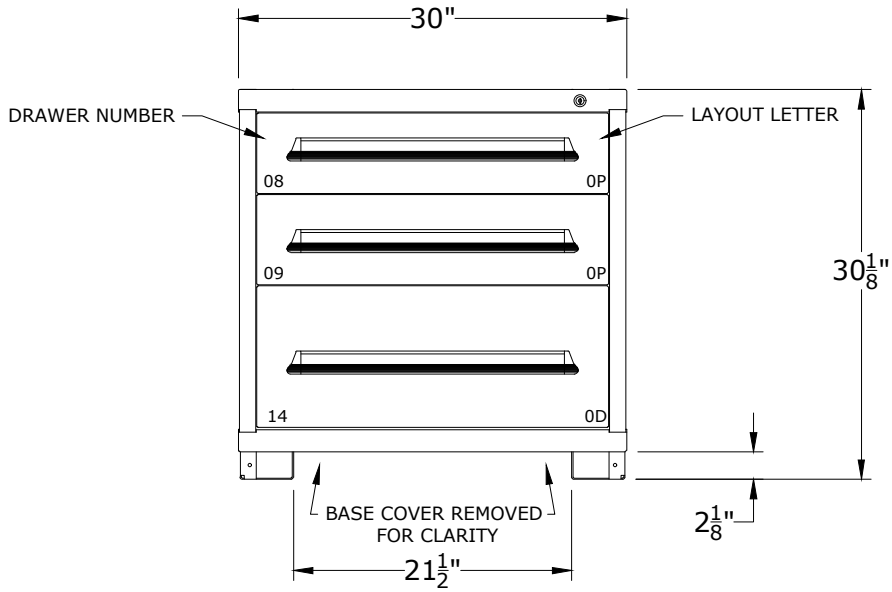

CABINET DEPTH @ 28-1/4" w/
FULL EXTENSION, 450lb. CAPACITY DRAWERS
EACH @ 25-1/8"W x 25-1/8"D USABLE

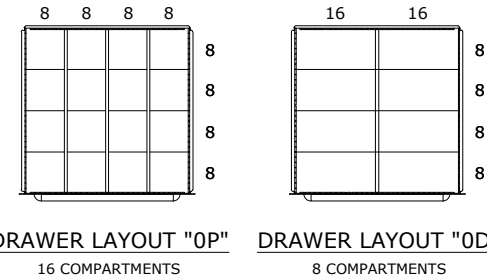

*OTHER LOCK OPTIONS AVAILABLE, CONTACT FOR DETAILS

DRAWER NUMBER	04	05	06	07	08	09	10	11	12	13	14	15	16	17	18
USABLE HEIGHT	2 $\frac{1}{4}$ "	3"	3 $\frac{7}{8}$ "	4 $\frac{5}{8}$ "	5 $\frac{3}{8}$ "	6 $\frac{1}{4}$ "	7"	7 $\frac{3}{4}$ "	8 $\frac{1}{2}$ "	9 $\frac{3}{8}$ "	10 $\frac{1}{8}$ "	10 $\frac{7}{8}$ "	11 $\frac{3}{4}$ "	12 $\frac{1}{2}$ "	13 $\frac{1}{4}$ "

LYON			P.O. Box 671 AURORA, IL 60507-0671 PHONE: 800-323-0082 www.lyonworkspace.com
<small>NOTICE: THIS DOCUMENT IS CONFIDENTIAL AND PROPRIETARY. NO PART OF THIS DOCUMENT MAY BE DISCLOSED TO A THIRD PARTY WITHOUT THE PRIOR WRITTEN CONSENT OF LYON LLC</small>			
DATE 07/05/17	DRAWN BY JR	CHECKED BY DWV	
DESCRIPTION PRE-ENGINEERED CABINET TABLE - STANDARD (3) DRAWERS (40) COMPARTMENTS			
SHEET	DRAWING NUMBER <i>3130301013</i>	REV 1	