

| | | | | | | | | | | | | | | |
|-------------------|-------------------|---------------------|-------------------|-------------------|--------------------|-------------------|---------------------|-------------------|-------------------|--------------------|-------------------|----------------------|--------------------|--------------------|
| COMPARTMENT SIZE | 3 | 4 | 5 | 6 | 7 | 8 | 9 | 10 | 11 | 12 | 13 | 14 | 15 | 16 |
| DIMENSION (CLEAR) | 1 $\frac{7}{8}$ " | 2 $\frac{11}{16}$ " | 3 $\frac{1}{2}$ " | 4 $\frac{1}{4}$ " | 5 $\frac{1}{16}$ " | 5 $\frac{7}{8}$ " | 6 $\frac{11}{16}$ " | 7 $\frac{1}{2}$ " | 8 $\frac{1}{4}$ " | 9 $\frac{1}{16}$ " | 9 $\frac{7}{8}$ " | 10 $\frac{11}{16}$ " | 11 $\frac{1}{2}$ " | 12 $\frac{1}{4}$ " |

PART NUMBER OPTIONS:

- S35303010320L** = SINGLE DRAWER ACCESS / NO LAYOUTS
- S35303010321L** = SINGLE DRAWER ACCESS / LAYOUTS FACTORY INSTALLED
- M35303010320L** = MULTIPLE DRAWER ACCESS / NO LAYOUTS
- M35303010321L** = MULTIPLE DRAWER ACCESS / LAYOUTS FACTORY INSTALLED
- N35303010320N** = NO LOCKING SYSTEM / NO LAYOUTS
- N35303010321N** = NO LOCKING SYSTEM / LAYOUTS FACTORY INSTALLED

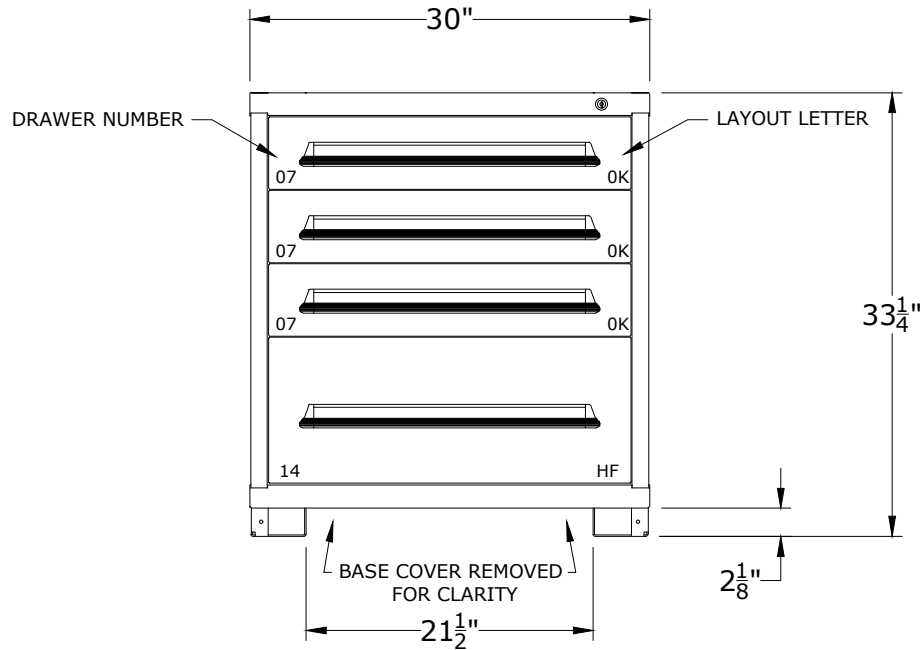

CABINET DEPTH @ 28-1/4" w/
 FULL EXTENSION, 450lb. CAPACITY DRAWERS
 EACH @ 25-1/8"W x 25-1/8"D USABLE

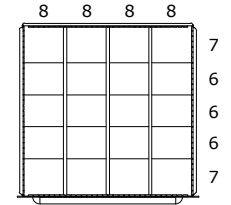

DRAWER LAYOUT "OK"
 20 COMPARTMENTS

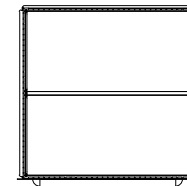

DRAWER LAYOUT "HF"
 (2) HANGING FILE FRAMES

*OTHER LOCK OPTIONS AVAILABLE, CONTACT FOR DETAILS

| | | | | | | | | | | | | | | | |
|---------------|-------------------|----|-------------------|-------------------|-------------------|-------------------|----|-------------------|-------------------|-------------------|--------------------|--------------------|--------------------|--------------------|--------------------|
| DRAWER NUMBER | 04 | 05 | 06 | 07 | 08 | 09 | 10 | 11 | 12 | 13 | 14 | 15 | 16 | 17 | 18 |
| USABLE HEIGHT | 2 $\frac{1}{4}$ " | 3" | 3 $\frac{7}{8}$ " | 4 $\frac{5}{8}$ " | 5 $\frac{3}{8}$ " | 6 $\frac{1}{4}$ " | 7" | 7 $\frac{3}{4}$ " | 8 $\frac{1}{2}$ " | 9 $\frac{3}{8}$ " | 10 $\frac{1}{8}$ " | 10 $\frac{7}{8}$ " | 11 $\frac{3}{4}$ " | 12 $\frac{1}{2}$ " | 13 $\frac{1}{4}$ " |

| | | | |
|--|----------------|---|-----|
| | | P.O. Box 671 AURORA, IL 60507-0671 PHONE: 800-323-0082 www.lyonworkspace.com | |
| | | NOTICE: THIS DOCUMENT IS CONFIDENTIAL AND PROPRIETARY. NO PART OF THIS DOCUMENT MAY BE DISCLOSED TO A THIRD PARTY WITHOUT THE PRIOR WRITTEN CONSENT OF LYON LLC | |
| DATE | DRAWN BY | CHECKED BY | |
| 06-26-17 | JR | DWV | |
| DESCRIPTION | | | |
| PRE-ENGINEERED CABINET BENCH - STANDARD (4) DRAWERS (62) COMPARTMENTS | | | |
| SHEET | DRAWING NUMBER | | REV |
| | 3530301032 | | 1 |