

DRAWER LABEL ASSEMBLY

LABEL CONTENTS OF DRAWER ON CARDBOARD LABEL. PLACE A LABEL PROTECTOR OVER THE CARDBOARD LABEL, AND INSERT BOTH INTO SLOT OF RIGHT HAND END CAP AS SHOWN. LABEL AND PROTECTOR WILL "DROP" INTO PLACE WHEN FULLY INSERTED. TO REMOVE, PUSH LABEL AND PROTECTOR UP SLIGHTLY BEFORE SLIDING TO THE RIGHT. IF INSTALLING ON SLIMLINE CABINET, CUT LABEL AND PROTECTOR TO A LENGTH OF 13-3/8" BEFORE INSERTING INTO DRAWER HANDLE.

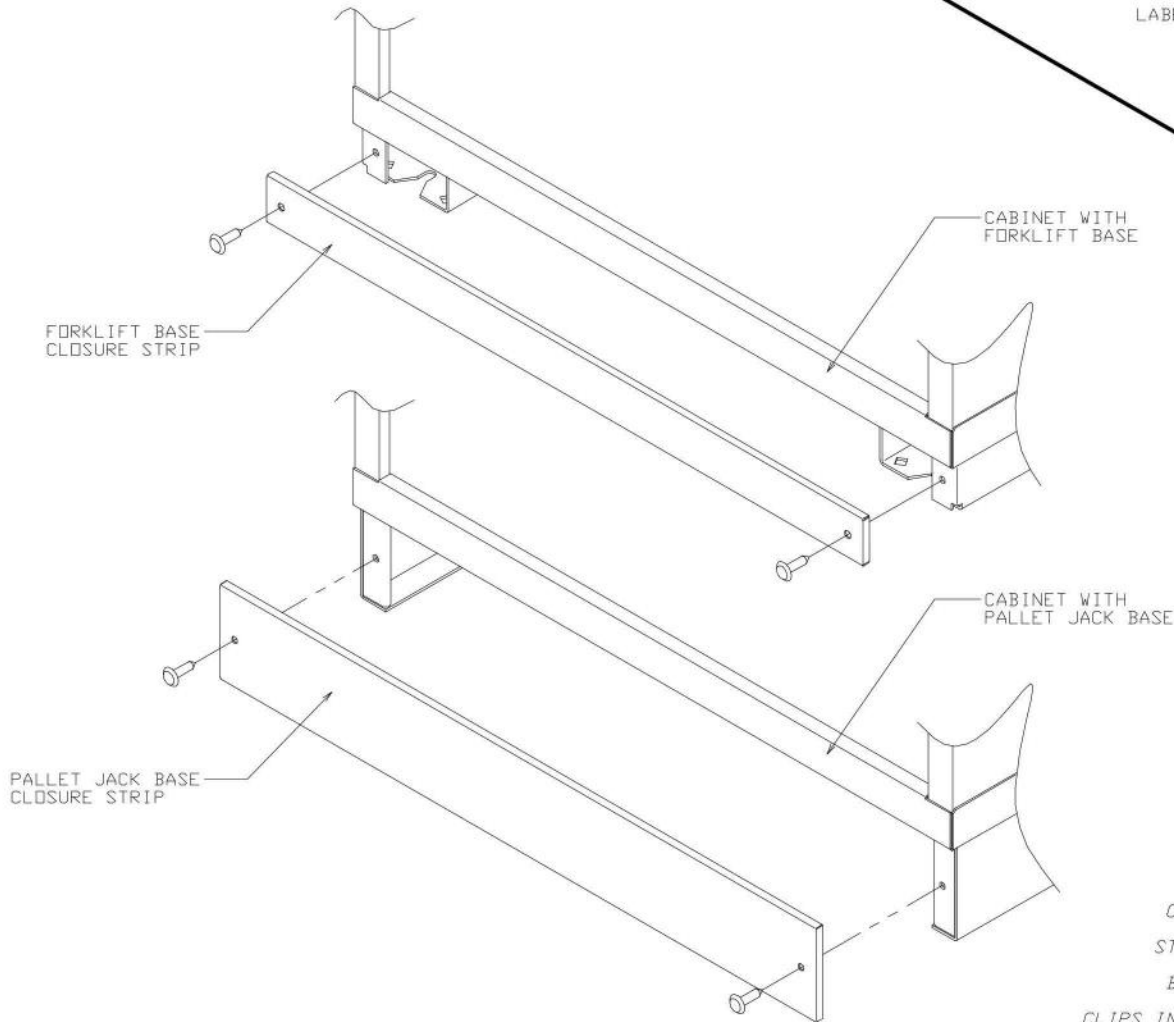
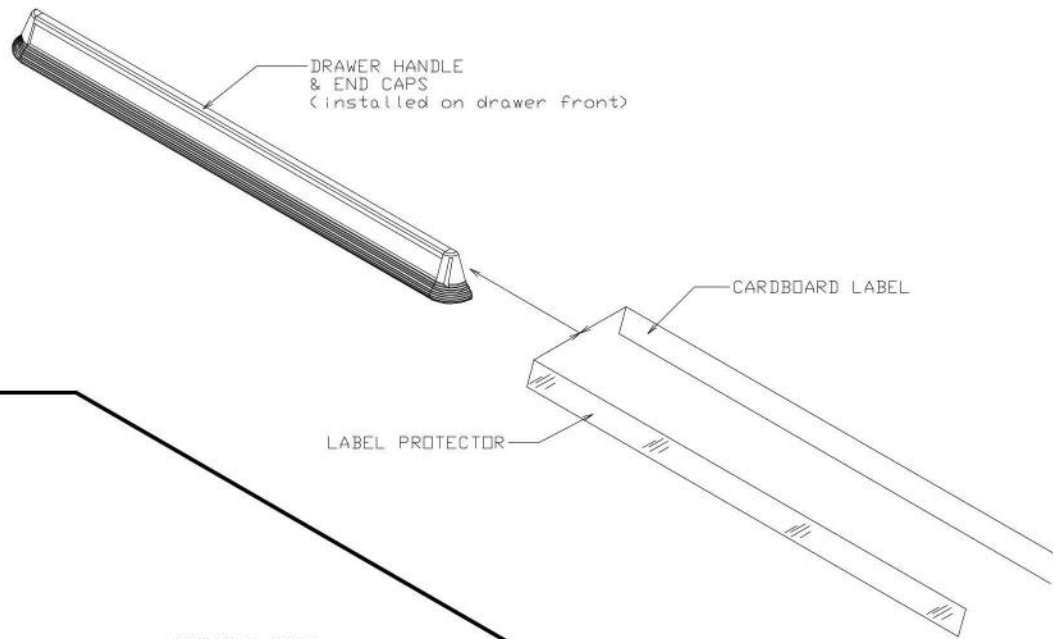

CLOSURE ASSEMBLY

PRESS TWO (2) BLACK TREE CLIPS INTO HOLES ON CLOSURE STRIP. ATTACH THIS ASSEMBLY BY PRESSING END OF THE TREE CLIPS INTO HOLES ON BASE CHANNELS.

LYON P.O. Box 671
AURORA, IL 60507-0671
PHONE: 630-892-8941
FAX: 800-367-6681

NOTICE: THIS IS A CONFIDENTIAL DISCLOSURE LOANED BY LYON WORKSPACE FOR REFERENCE PURPOSES ONLY

DATE 01-28-12	DRAWN BY JR	CHECKED BY DWV
------------------	----------------	-------------------

DESCRIPTION

INSTALLATION
CLOSURE STRIP/DRW LABEL
MDC

SHEET -	DRAWING NUMBER SS1324	REV 1
------------	---------------------------------	----------