

COMPARTMENT SIZE	3	4	5	6	7	8	9	10	11	12	13	14	15	16
DIMENSION (CLEAR)	1 $\frac{7}{8}$ "	2 $\frac{11}{16}$ "	3 $\frac{1}{2}$ "	4 $\frac{1}{4}$ "	5 $\frac{1}{16}$ "	5 $\frac{7}{8}$ "	6 $\frac{11}{16}$ "	7 $\frac{1}{2}$ "	8 $\frac{1}{4}$ "	9 $\frac{1}{16}$ "	9 $\frac{7}{8}$ "	10 $\frac{11}{16}$ "	11 $\frac{1}{2}$ "	12 $\frac{1}{4}$ "

PART NUMBER OPTIONS;

**S35303010190L** = SINGLE DRAWER ACCESS / NO LAYOUTS

**S35303010191L** = SINGLE DRAWER ACCESS / LAYOUTS FACTORY INSTALLED

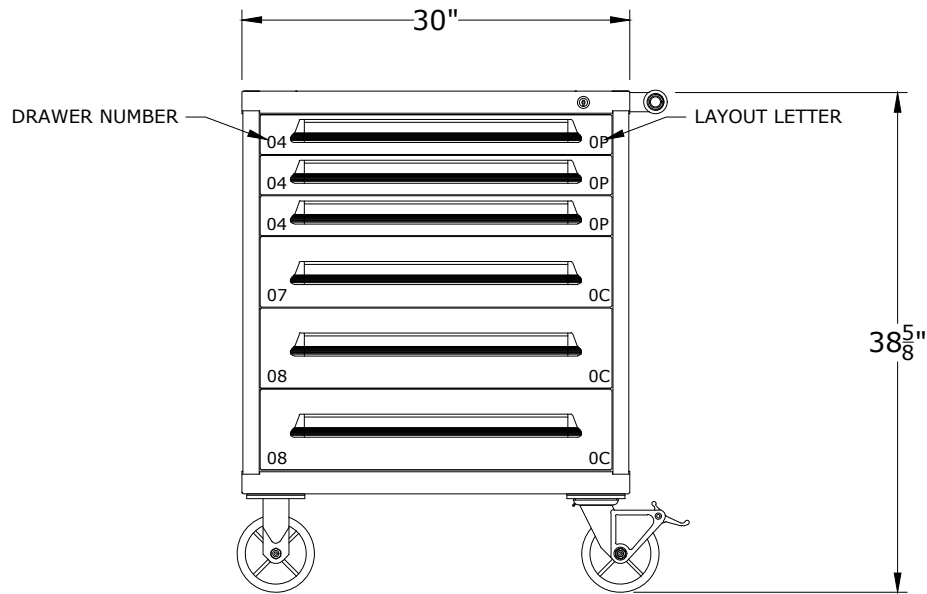

CABINET DEPTH @ 28-1/4" w/  
FULL EXTENSION, 450lb. CAPACITY DRAWERS  
EACH @ 25-1/8"W x 25-1/8"D USABLE

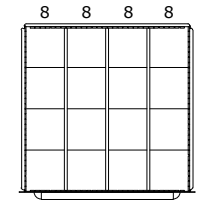

**DRAWER LAYOUT "0P"**  
16 COMPARTMENTS

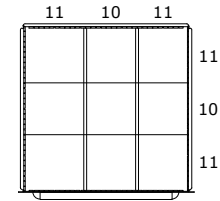

**DRAWER LAYOUT "0C"**  
9 COMPARTMENTS

\*OTHER LOCK OPTIONS AVAILABLE, CONTACT FOR DETAILS

DRAWER NUMBER	04	05	06	07	08	09	10	11	12	13	14	15	16	17	18
USABLE HEIGHT	2 $\frac{1}{4}$ "	3"	3 $\frac{7}{8}$ "	4 $\frac{5}{8}$ "	5 $\frac{3}{8}$ "	6 $\frac{1}{4}$ "	7"	7 $\frac{3}{4}$ "	8 $\frac{1}{2}$ "	9 $\frac{3}{8}$ "	10 $\frac{1}{8}$ "	10 $\frac{7}{8}$ "	11 $\frac{3}{4}$ "	12 $\frac{1}{2}$ "	13 $\frac{1}{4}$ "

**LYON** P.O. Box 671  
AURORA, IL 60507-0671  
PHONE: 800-323-0082  
www.lyonworkspace.com

NOTICE: THIS DOCUMENT IS CONFIDENTIAL AND PROPRIETARY. NO PART OF THIS DOCUMENT MAY BE DISCLOSED TO A THIRD PARTY WITHOUT THE PRIOR WRITTEN CONSENT OF LYON LLC

DATE 08/03/17	DRAWN BY JR	CHECKED BY DWV
------------------	----------------	-------------------

DESCRIPTION

**PRE-ENGINEERED  
MOBILE CABINET  
BENCH - STANDARD**

(6) DRAWERS  
(75) COMPARTMENTS

SHEET	DRAWING NUMBER 3530301019	REV 1
-------	------------------------------	----------