

CABINET DRILL PATTERNS  
(RIGHT SIDE SHOWN)

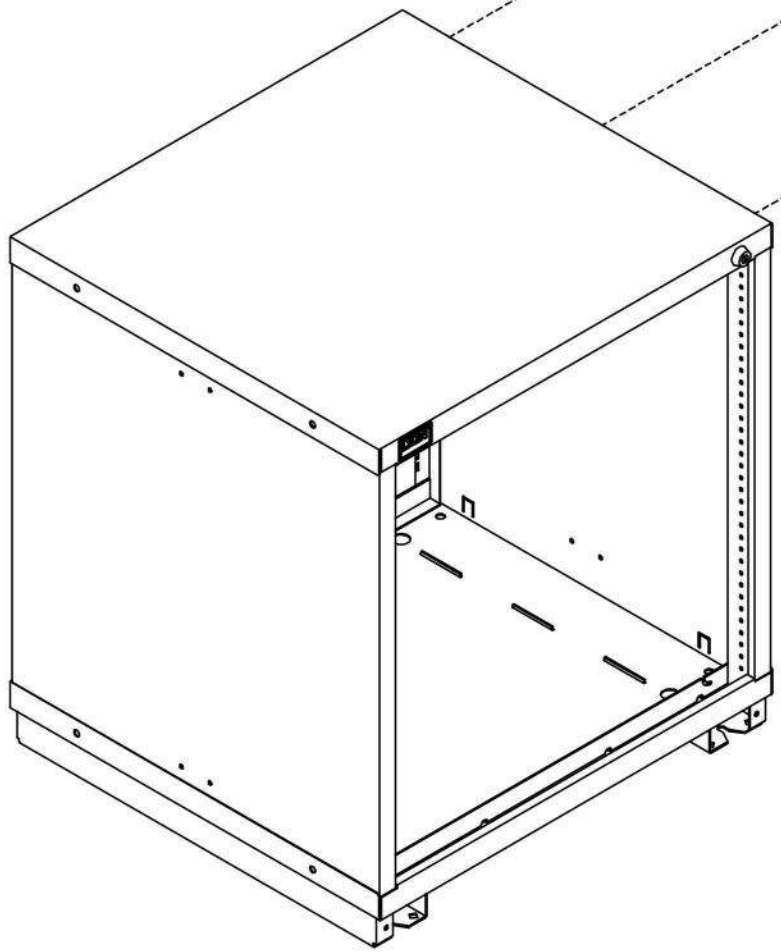
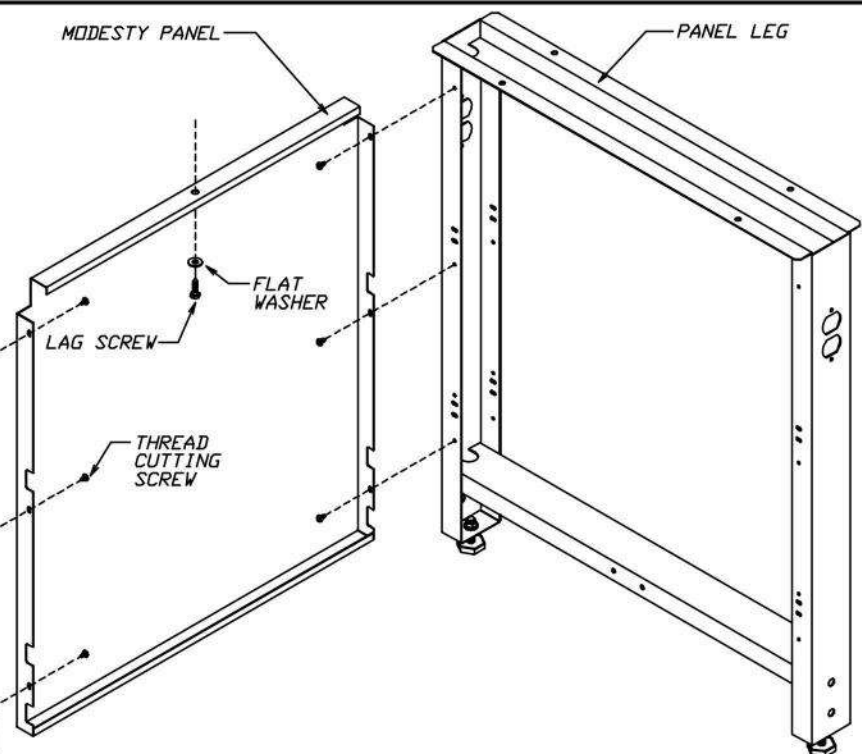

**ASSEMBLY INSTRUCTIONS**

DRILL EITHER TWO (2) or THREE (3) 0.166 DIAMETER HOLES ON THE SIDE OF THE CABINET WHICH IS TO ACCEPT ATTACHMENT OF THE MODESTY PANEL PER DRILL PATTERNS SHOWN ABOVE.

ATTACH MODESTY PANEL TO CABINET AND PANEL LEG AS SHOWN WITH SUPPLIED #10-24 THREAD CUTTING SCREWS. FOUR (4) SCREWS WILL BE REQUIRED FOR 270 and 310 HEIGHT CABINETS. SIX (6) SCREWS WILL BE REQUIRED FOR 350 and 400 HEIGHT CABINETS.

LASTLY, USING THE HOLE ON THE TOP FLANGE OF THE MODESTY PANEL AS A GUIDE, DRILL ONE (1) 13/64" DIAMETER 1" DEEP HOLE ON THE UNDERSIDE OF THE TOP (NOT SHOWN). ATTACH WITH THE 1/4" x 1" LAG SCREW AND 1/4" FLAT WASHER. (LUBRICATE THE SCREW THREADS PRIOR TO ASSEMBLY)

**SUPPLIED HARDWARE**

1/4 x 1" HEX HEAD LAG SCREW

1/4" FLAT WASHER

#10-24 THREAD CUTTING SCREW

|  |                                 |   |          |
|--|---------------------------------|---|----------|
| <b>LYON</b>  |                                 | P.O. Box 671<br>AURORA, IL 60507-0671<br>PHONE: 630-892-8941<br>FAX: 800-367-6681 |          |
| NOTICE: THIS IS A CONFIDENTIAL DISCLOSURE LOANED BY LYON WORKSPACE FOR REFERENCE PURPOSES ONLY |                                 |   |          |
| DATE<br>07-19-12   | DRAWN BY<br>JR                  | CHECKED BY<br>DWV   |          |
| DESCRIPTION<br><b>INSTALLATION<br/>MODESTY PANEL<br/>MDC</b>                                   |                                 |   |          |
| SHEET<br>1   | DRAWING NUMBER<br><b>SS1872</b> |   | REV<br>1 |