

TWO TOPS TO ONE CABINET

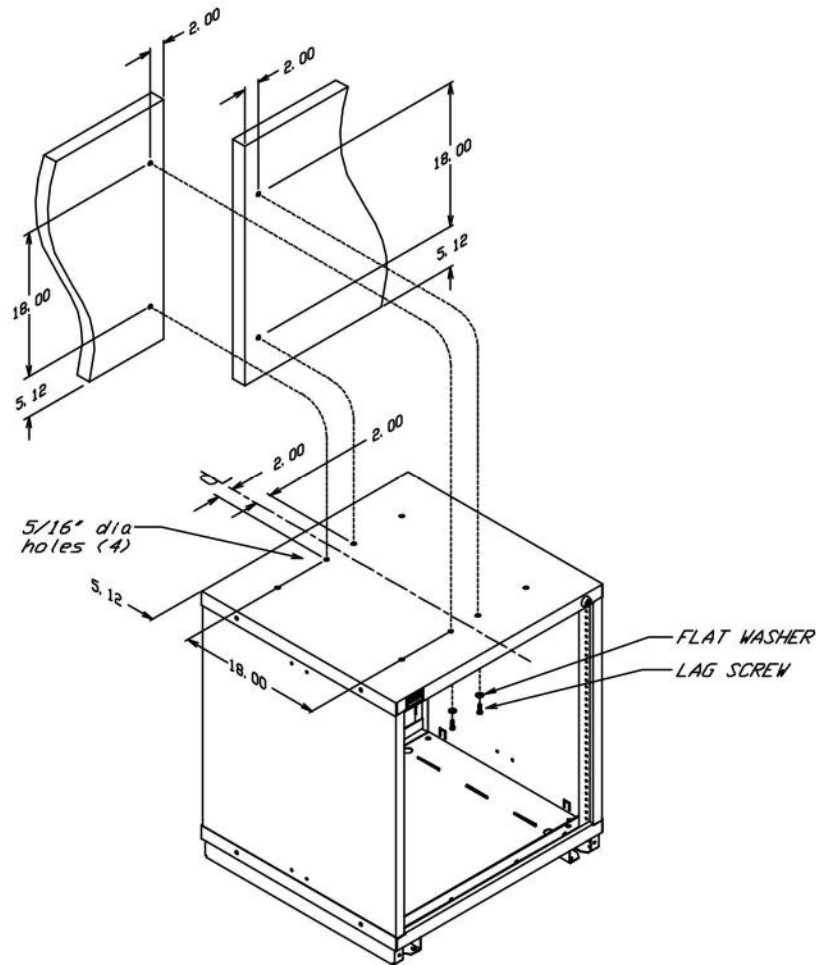

TOP ATTACHMENT for TWO TOPS to CABINET

Remove sufficient top drawers and carriers and mark for reinstallation.

Drill four (4) 5/16" diameter holes on the top of the Cabinet as shown.

Drill two (2) 13/64" diameter 1" deep holes on each underside of the Tops as shown.

Align the holes in the top of the Cabinet with the holes in the Tops. Attach with the 1/4" Lag Screws and 1/4" Flat Washers. (Lubricate the screw threads prior to assembly).

Replace drawers and carriers into specific locations and check for proper drawer operation.

TWO TOPS TO ONE PANEL LEG

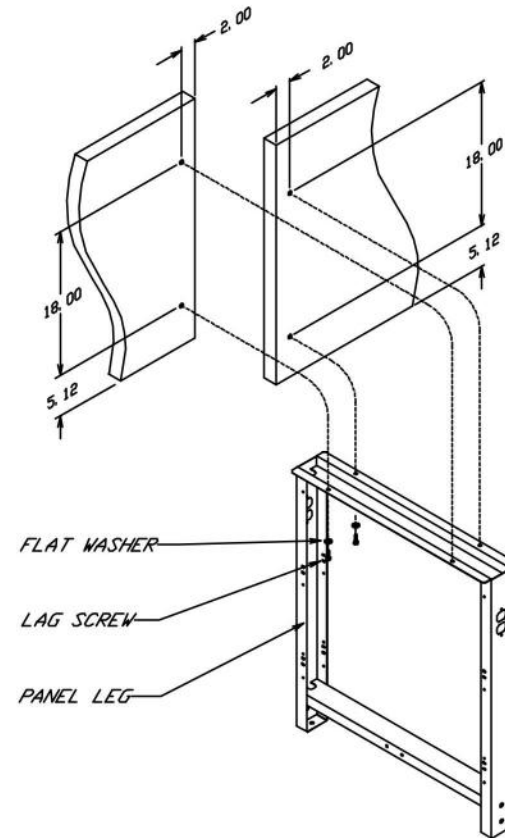

TOP ATTACHMENT for TWO TOPS to PANEL LEG

Drill two (2) 13/64" diameter 1" deep holes on each underside of the Tops as shown.

Align the holes in the top of the Panel Leg with the holes in the Tops. Attach with the 1/4" Lag Screws and 1/4" Flat Washers. (Lubricate the screw threads prior to assembly).

LYON		P.O. Box 671 AURORA, IL 60507-0671 PHONE: 630-892-8941 FAX: 800-367-6681	
		NOTICE: THIS IS A CONFIDENTIAL DISCLOSURE LOANED BY LYON WORKSPACE FOR REFERENCE PURPOSES ONLY	
DATE 07-19-12	DRAWN BY JR	CHECKED BY DWV	
DESCRIPTION INSTALLATION OPEN/CLOSED PANEL LEG MDC			
SHEET 2	DRAWING NUMBER SS1870		REV 1

**ONE TOP TO ONE
CABINET AND PANEL LEG**

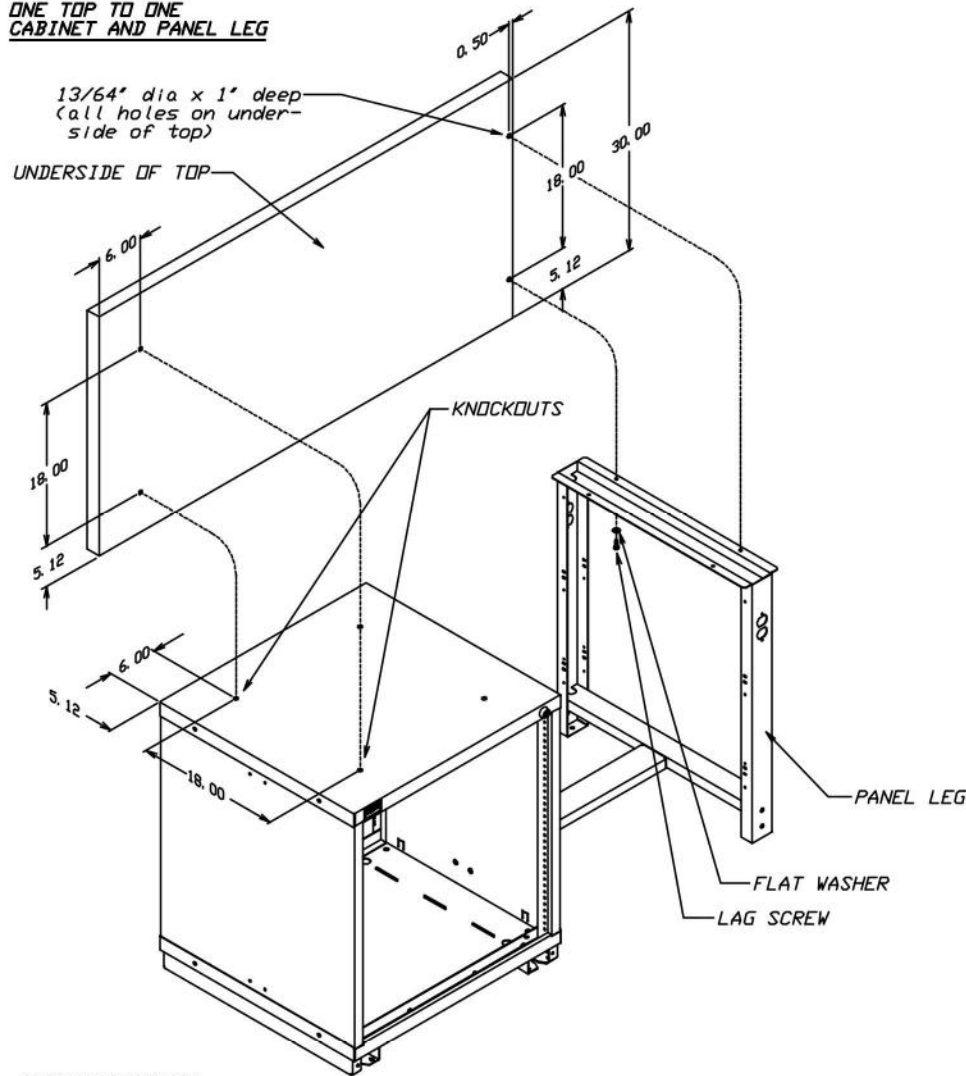

TOP ATTACHMENT

Drill four (4) 13/64" diameter 1" deep holes on the underside of the Top as shown.

Punch Knockouts as shown in top of cabinet and remove sufficient top drawers and carriers and mark for reinstallation.

Align the holes in the top of the Cabinet and Panel Leg with the holes in the Top. Attach with the 1/4" x 1" Lag Screws and 1/4" Flat Washers. (Lubricate the screw threads prior to assembly).

Replace drawers and carriers into specific locations and check for proper drawer operation.

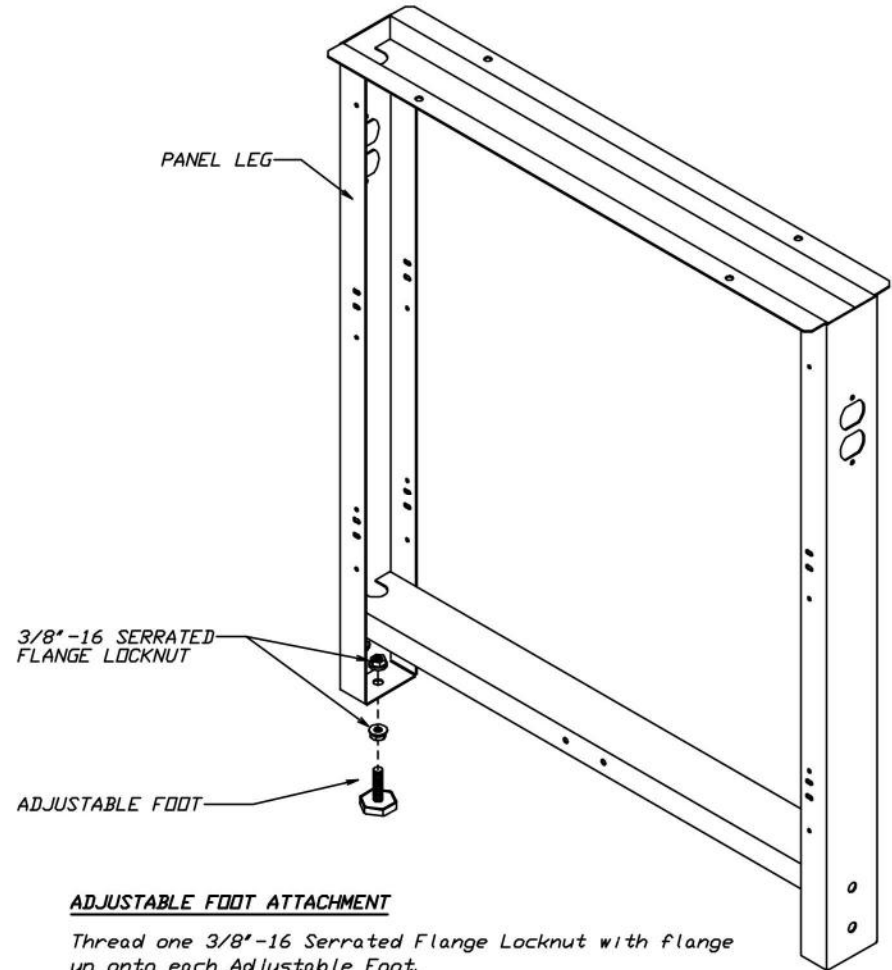

ADJUSTABLE FOOT ATTACHMENT

Thread one 3/8"-16 Serrated Flange Locknut with flange up onto each Adjustable Foot.

Insert this assembly into hole as shown on both sides of Panel Leg. Attach the other 3/8"-16 Serrated Flange Locknut with flange down onto each Adjustable Foot.

Adjust both feet for proper height.

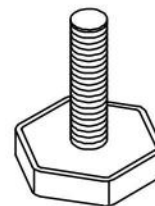

ADJUSTABLE FOOT



3/8"-16 SERRATED
FLANGE LOCKNUT



1/4" x 1" HEX HEAD LAG SCREW



1/4" FLAT WASHER

SUPPLIED HARDWARE

LYON P.O. Box 671
AURORA, IL 60507-0671
PHONE: 630-892-8941
FAX: 800-367-6681

NOTICE: THIS IS A CONFIDENTIAL DISCLOSURE LOANED BY LYON WORKSPACE FOR REFERENCE PURPOSES ONLY

DATE 07-19-12	DRAWN BY JR	CHECKED BY DWV
------------------	----------------	-------------------

DESCRIPTION

**INSTALLATION
OPEN/CLOSED PANEL LEG
MDC**

SHEET 1	DRAWING NUMBER SS1870	REV 1
------------	---------------------------------	----------