

CABINET DRILL PATTERN  
(RIGHT SIDE SHOWN)

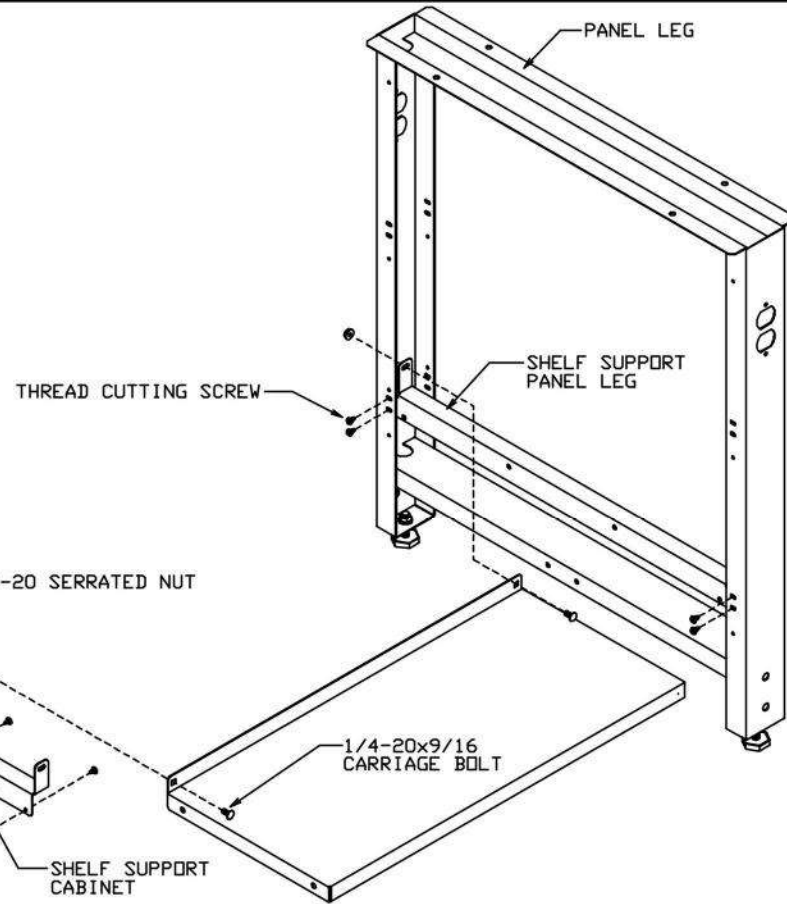

### ASSEMBLY INSTRUCTIONS

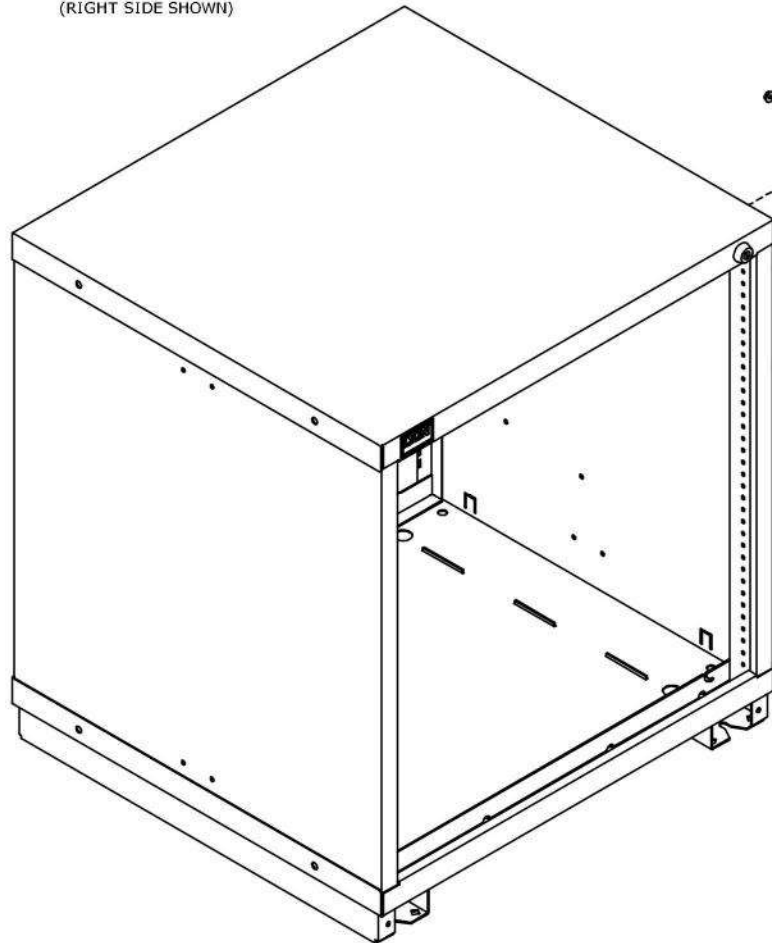

DRILL THREE (3) 0.166 DIAMETER HOLES ON THE SIDE OF THE CABINET WHICH IS TO ACCEPT ATTACHMENT OF THE SHELF SUPPORT PER DRILL PATTERN SHOWN ABOVE.

ATTACH BOTH SHELF SUPPORTS TO CABINET AND PANEL LEG WITH SUPPLIED #10-24 THREAD CUTTING SCREWS.

ATTACH SHELF TO SUPPORTS WITH SUPPLIED 1/4-20x9/16 CARRIAGE SCREWS AND 1/4-20 SERRATED FLANGE NUTS.

SEE BACK SIDE OF SHEET FOR OTHER OPTIONS.

SUPPLIED HARDWARE

-  1/4-20x9/16 CARRIAGE SCREW
-  1/4-20 SERRATED FLANGE NUT
-  #10-24 THREAD CUTTING SCREW

**LYON** P.O. Box 671  
AURORA, IL 60507-0671  
PHONE: 630-892-8941  
FAX: 800-367-6681

NOTICE: THIS IS A CONFIDENTIAL DISCLOSURE LOANED BY LYON WORKSPACE FOR REFERENCE PURPOSES ONLY

DATE 07-19-12	DRAWN BY JR	CHECKED BY DWV
------------------	----------------	-------------------

DESCRIPTION

**INSTALLATION  
UNDER COUNTER SHELF  
MDC**

SHEET 1	DRAWING NUMBER <b>SS1874</b>	REV 1
------------	---------------------------------	----------

# SHELF PLACEMENT OPTIONS FOR 350 and 400 HEIGHT CABINETS

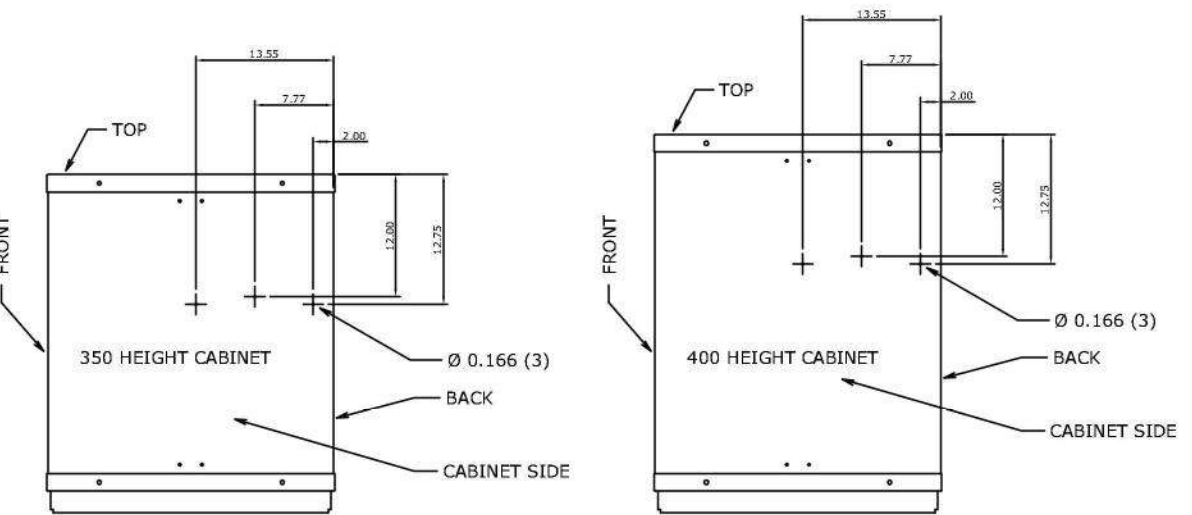
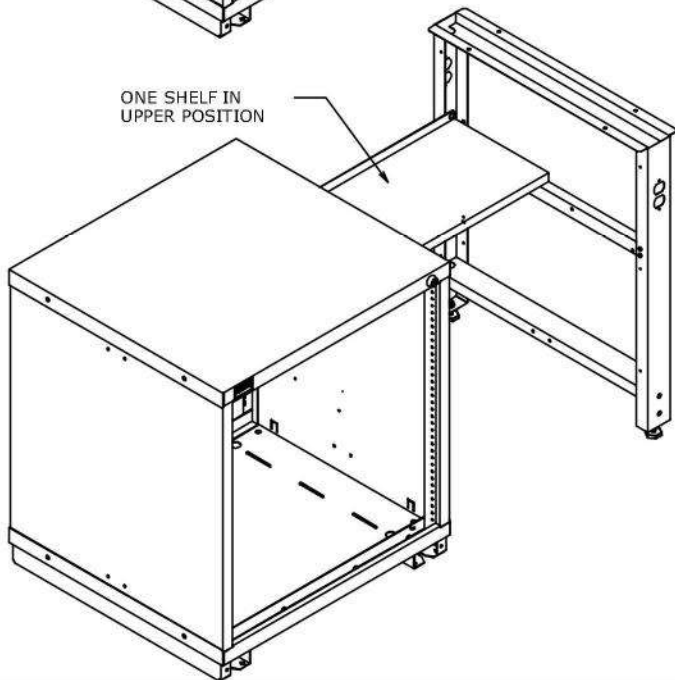
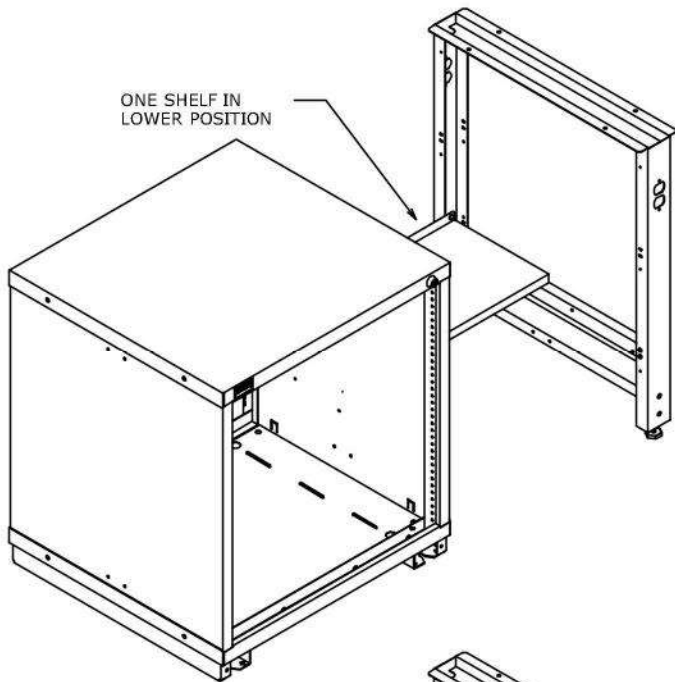

CABINET DRILL PATTERN  
(RIGHT SIDE SHOWN)

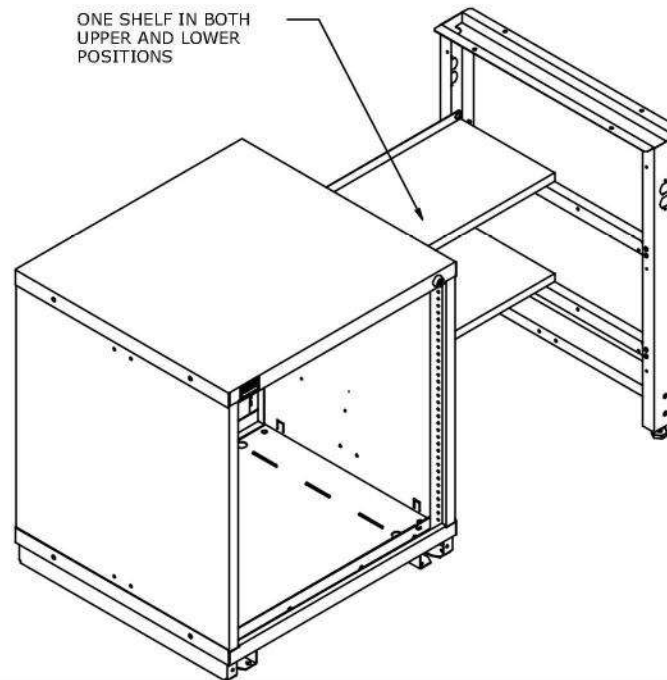

## ASSEMBLY INSTRUCTIONS

YOU HAVE THE OPTION ON BOTH THE 350 and 400 HEIGHT CABINETS TO ATTACH THE UNDERCOUNTER SHELF IN ONE OF TWO POSITIONS OR IN BOTH POSITIONS AS SHOWN.

THE DRILL PATTERN SHOWN ABOVE HAS DIMENSIONS FOR THE UPPER POSITION.

FOLLOW INSTRUCTIONS AS SHOWN ON OPPOSITE SIDE FOR ATTACHMENT.

<b>LYON</b>		P.O. Box 671 AURORA, IL 60507-0671 PHONE: 630-892-8941 FAX: 800-367-6681
NOTICE: THIS IS A CONFIDENTIAL DISCLOSURE LOANED BY LYON WORKSPACE FOR REFERENCE PURPOSES ONLY		
DATE 07-19-12	DRAWN BY JR	CHECKED BY DWV
DESCRIPTION <b>INSTALLATION SHELF PLACEMENT OPTIONS MDC</b>		
SHEET 2	DRAWING NUMBER <b>SS1874</b>	REV 1