

TWO TOPS TO ONE CABINET

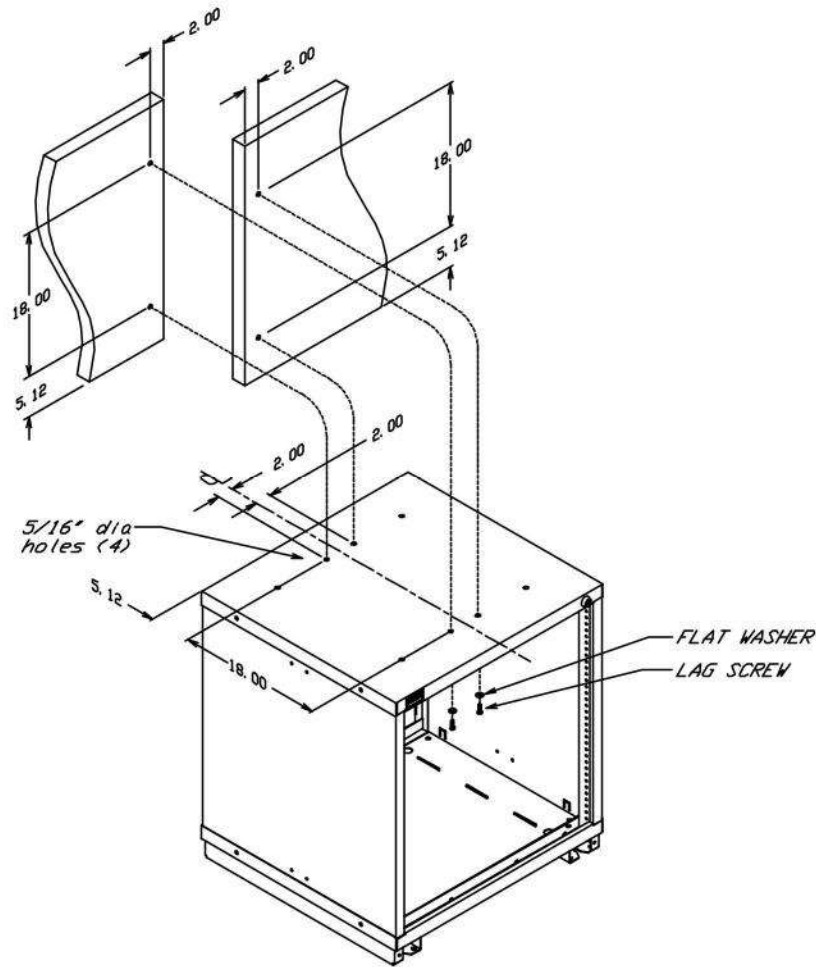

TOP ATTACHMENT for TWO TOPS to CABINET

Remove sufficient top drawers and carriers and mark for reinstallation.

Drill four (4) 5/16" diameter holes on the top of the Cabinet as shown.

Drill two (2) 13/64" diameter 1" deep holes on each underside of the Tops as shown.

Align the holes in the top of the Cabinet with the holes in the Tops. Attach with the 1/4" Lag Screws and 1/4" Flat Washers. (Lubricate the screw threads prior to assembly).

Replace drawers and carriers into specific locations and check for proper drawer operation.

TWO TOPS TO ONE PANEL LEG

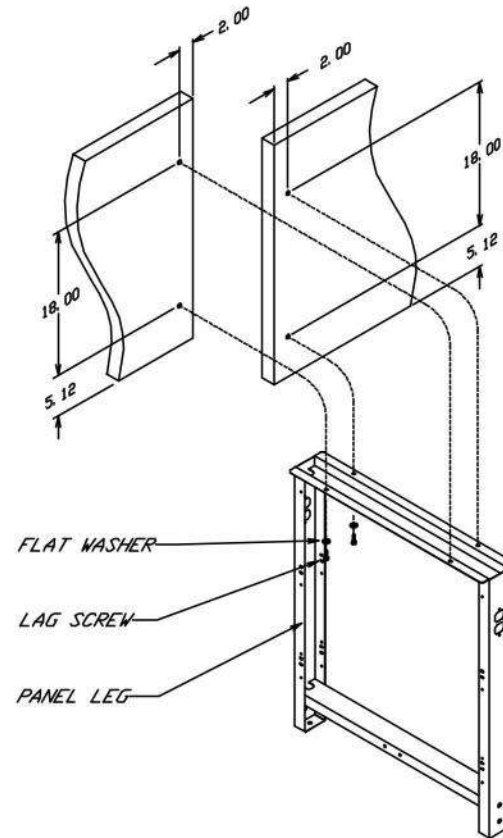

TOP ATTACHMENT for TWO TOPS to PANEL LEG

Drill two (2) 13/64" diameter 1" deep holes on each underside of the Tops as shown.

Align the holes in the top of the Panel Leg with the holes in the Tops. Attach with the 1/4" Lag Screws and 1/4" Flat Washers. (Lubricate the screw threads prior to assembly).

<b>LYON</b>		P.O. Box 671 AURORA, IL 60507-0671 PHONE: 630-892-8941 FAX: 800-367-6681	
		NOTICE: THIS IS A CONFIDENTIAL DISCLOSURE LOANED BY LYON WORKSPACE FOR REFERENCE PURPOSES ONLY	
DATE 07-19-12	DRAWN BY JR	CHECKED BY DWV	
DESCRIPTION <b>INSTALLATION OPEN/CLOSED PANEL LEG MDC</b>			
SHEET 2	DRAWING NUMBER <b>SS1870</b>		REV 1