

# GENERAL INSTRUCTIONS

1.) BEFORE INSTALLING MODULAR DRAWER UNITS, IT MUST BE VERIFIED THAT THE UPRIGHTS ARE PLUMB AND THE SHELVES ARE LEVEL. THE SHELVING UNIT MUST ALSO BE PROPERLY ANCHORED AS DESCRIBED IN THE INSTALLATION SHEET PROVIDED WITH THE SHELVING UNIT. IF NEEDED, CONTACT LYON CUSTOMER SERVICE FOR PROPER ANCHORING METHODS. DRAWERS WILL NOT OPERATE CORRECTLY IF THE ABOVE CRITERIA IS NOT MET.

2.) EACH UNIT MUST HAVE A SHELF ABOVE AND BELOW THE UNIT. TWO UNITS IN ONE SHELVING SECTION MUST BE SEPARATED BY A SHELF. ONE 18" UNIT (25 SEGMENTS) REQUIRES A SPACE OF 22 1/2", AND ONE 36" UNIT (48 SEGMENTS) REQUIRES A SPACE OF 40 1/2". THIS SPACE IS MEASURED FROM TOP OF SHELF TO TOP OF SHELF.

3.) MODULAR DRAWERS ARE AVAILABLE IN THE FOLLOWING SIZES:

PART #	FRONT HEIGHT	USABLE HEIGHT	SEGMENTS
N043030NN000	3 1/16"	2 1/4"	4
N053030NN000	3 7/8"	3"	5
N063030NN000	4 5/16"	3 7/8"	6
N073030NN000	5 7/16"	4 5/8"	7
N083030NN000	6 3/16"	5 3/8"	8
N093030NN000	7"	6 1/4"	9
N103030NN000	7 3/4"	7"	10
N113030NN000	8 9/16"	7 3/4"	11
N123030NN000	9 3/8"	8 1/2"	12
N133030NN000	10 1/4"	9 3/8"	13
N143030NN000	10 7/8"	10 1/8"	14
N153030NN000	11 3/4"	10 7/8"	15
N163030NN000	12 1/2"	11 3/4"	16
N173030NN000	13 5/16"	12 1/2"	17
N183030NN000	14 1/16"	13 1/4"	18

ANY COMBINATION OF DRAWER SEGMENTS TOTALING 25 FOR THE 18" UNIT OR 48 FOR THE 36" UNIT MAY BE USED

## PARTS IDENTIFICATION:

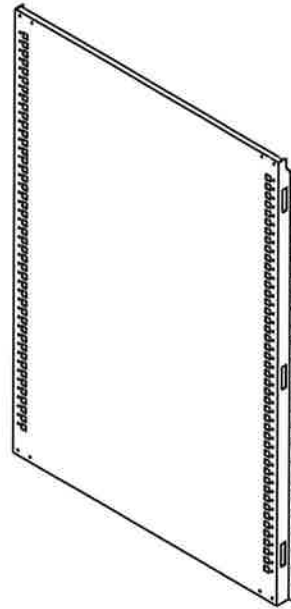

MOUNTING PANEL  
(2 PIECES)



VERTICAL TRIM  
(2 PIECES)

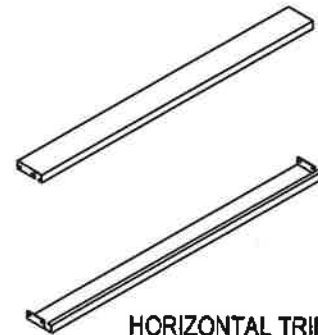

HORIZONTAL TRIM  
(2 PIECES)

### SUPPLIED FASTENERS:

SHOWN ACTUAL SIZE

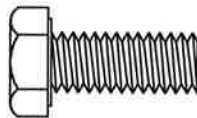

5/16"-18 X 3/4"  
HEX HEAD CAP SCREW  
(8 PIECES)



5/16"-18 HEX NUT  
(8 PIECES)



#8-32 x 3/8"  
FLAT HEAD TAPPING SCREW  
(8 PIECES)

SHEET 1

## IN NEED OF ASSEMBLY ASSISTANCE?

Contact us direct for fast friendly service (800) 323-0082

Int'l calls (630) 892-8941 | WEB: [www.lyonworkspace.com](http://www.lyonworkspace.com)

ASSEMBLY INSTRUCTIONS  
FOR LYON MODULAR  
DRAWERS IN SHELVING

**LYON**

LYON L.L.C.  
P.O. BOX 871  
AURORA, IL 60507

**9116-CA**

# ASSEMBLY OPERATION #1

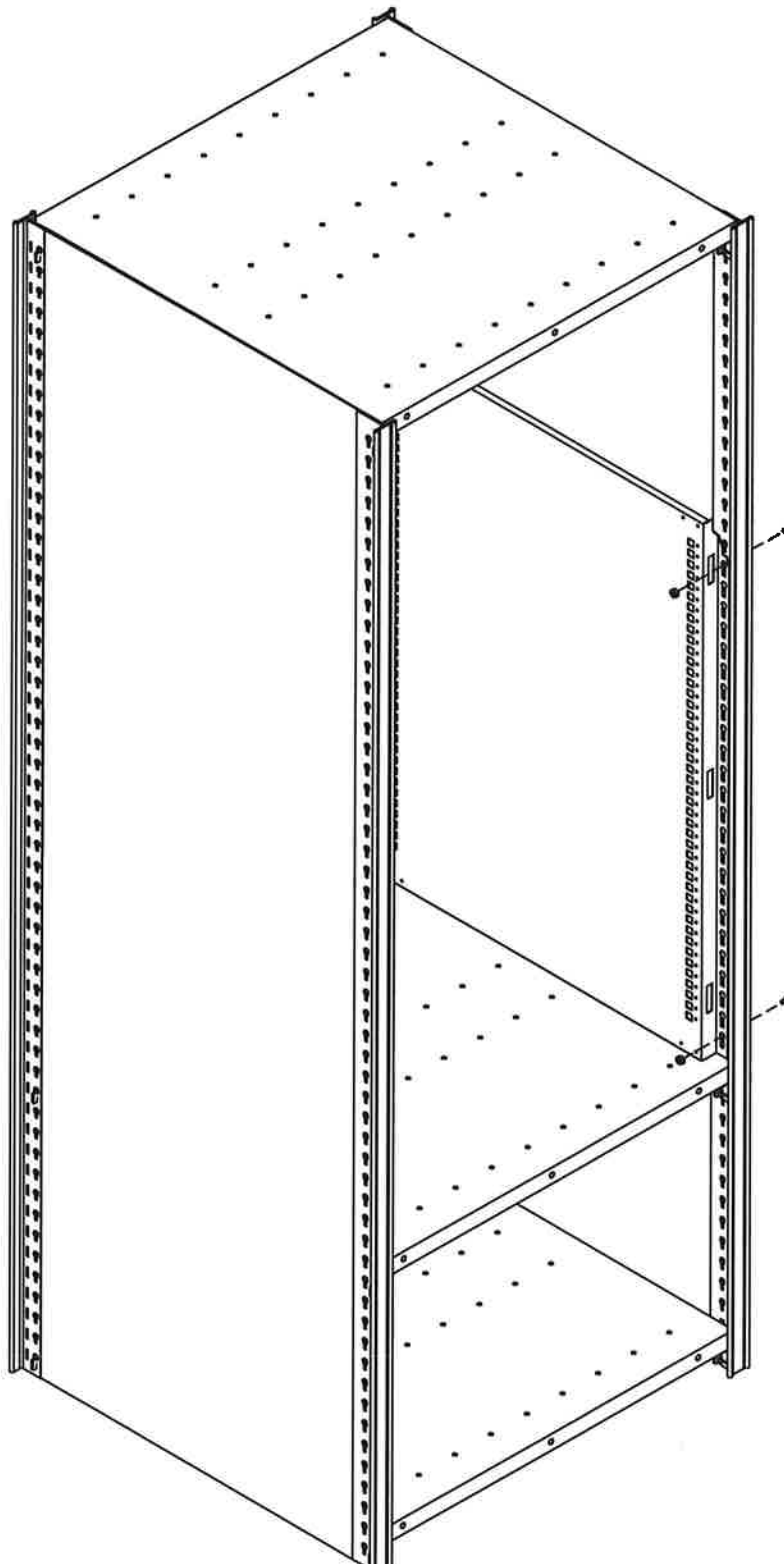

- 1.) DETERMINE DESIRED SHELF SPACING WITHIN SHELVING SECTION. ASSEMBLE SHELVING AS DESCRIBED IN THE INSTALLATION SHEET PROVIDED WITH THE SHELVING UNIT, OMITTING THE SHELF DIRECTLY ABOVE THE MODULAR DRAWER UNIT. ONE 18" UNIT (25 SEGMENTS) REQUIRES A SPACE OF 22 1/2", AND ONE 36" UNIT (48 SEGMENTS) REQUIRES A SPACE OF 40 1/2". BE SURE TO ATTACH THE SHELVING BACKS TO THE SHELVES FOR STABILITY.
- 2.) ATTACH THE MOUNTING PANELS TO THE UPRIGHTS WITH 5/16" NUT AND BOLT, 4 PLACES EACH PANEL. WHEN ASSEMBLING A ROW OF SHELVING WITH MATCHING MODULAR DRAWER UNITS, THE SAME BOLT CAN BE USED TO ATTACH ADJACENT MOUNTING PANELS TO A SINGLE SHELVING UPRIGHT.

NOTE: 36" HIGH (48 SEGMENT) MOUNTING PANEL SHOWN, 18" (25 SEGMENT) SIMILAR

## REQUIRED HARDWARE:

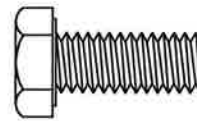

5/16"-18 X 3/4"  
HEX HEAD CAP SCREW  
(8 PIECES)



5/16"-18 HEX NUT  
(8 PIECES)

SHEET 2

## IN NEED OF ASSEMBLY ASSISTANCE?

Contact us direct for fast friendly service (800) 323-0082

Int'l calls (630) 892-8941 | WEB: [www.lyonworkspace.com](http://www.lyonworkspace.com)

ASSEMBLY INSTRUCTIONS  
FOR LYON MODULAR  
DRAWERS IN SHELVING

**LYON**

LYON L.L.C.  
P.O. BOX 671  
AURORA, IL 60507

**9116-CA**

## ASSEMBLY OPERATION #2

1.) ATTACH VERTICAL TRIM TO MOUNTING PANEL BY ALIGNING TANGS TO SLOTS IN PANEL, AND SLIDING TRIM DOWN

2.) ASSEMBLE HORIZONTAL TRIM PIECE AT THE BOTTOM OF THE UNIT ONLY. USE (4) #8 TAPPING SCREWS TO ATTACH.

NOTE: THE TRIM PIECES ARE ONLY USED AT THE FRONT OF THE SHELVING SECTION.

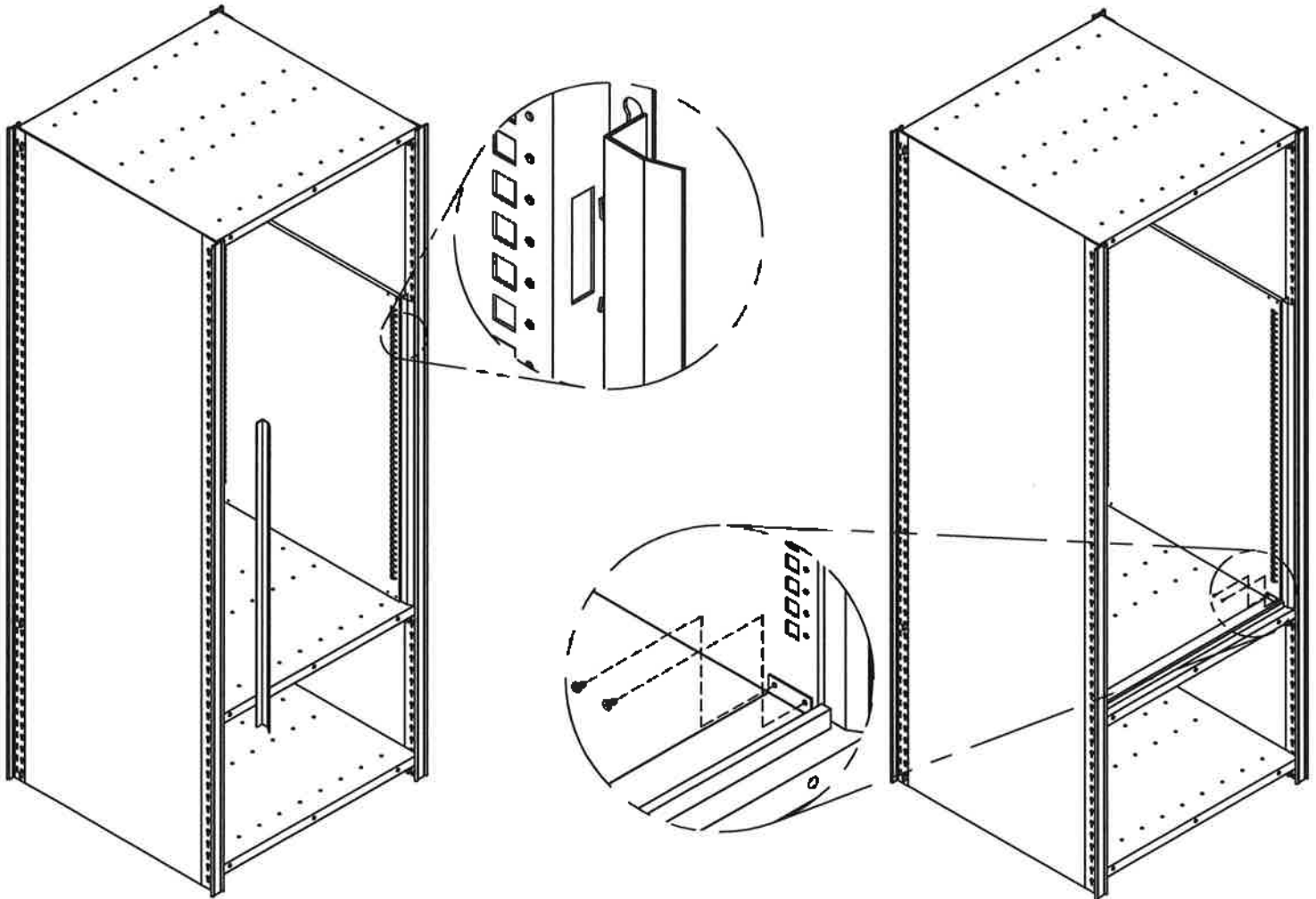

### REQUIRED HARDWARE:



#8-32 x 3/8"  
FLAT HEAD TAPPING SCREW  
(4 PIECES)

SHEET 3

**IN NEED OF  
ASSEMBLY ASSISTANCE?**

Contact us direct for fast friendly service (800) 323-0082

Int'l calls (630) 892-8941 | WEB: [www.lyonworkspace.com](http://www.lyonworkspace.com)

ASSEMBLY INSTRUCTIONS  
FOR LYON MODULAR  
DRAWERS IN SHELVING

**LYON**

LYON L.L.C.  
P.O. BOX 871  
AURORA, IL 60507

**9116-CA**

# ASSEMBLY OPERATION #3

- 1.) BEGINNING AT THE BOTTOM OF THE MOUNTING PANEL, ATTACH THE STATIONARY PORTION OF THE DRAWER SLIDE BY ALIGNING THE SLIDE'S REAR TAB INTO THE LOWEST SQUARE HOLE IN THE REAR OF THE MOUNTING PANEL. THEN, ALIGN THE FRONT TAB TO THE SQUARE HOLE IN THE FRONT OF THE MOUNTING PANEL AND PRESS DOWN. WHEN THE SLIDE IS SEATED, THE #8 SCREW SHOULD BE INSERTED TO SECURE THE SLIDE IN PLACE. (SEE DETAIL AT RIGHT)

- 2.) PROCEED WITH INSTALLING THE MIDDLE SECTION OF THE DRAWER SLIDES. PAY ATTENTION TO RIGHT HAND AND LEFT HAND WHEN ASSEMBLING. AFTER THE MIDDLE SECTIONS OF THE SLIDES ARE INSERTED, MAKE SURE THE SAFETY CATCHES ARE UNLOCKED BEFORE ATTEMPTING TO INSERT A DRAWER.

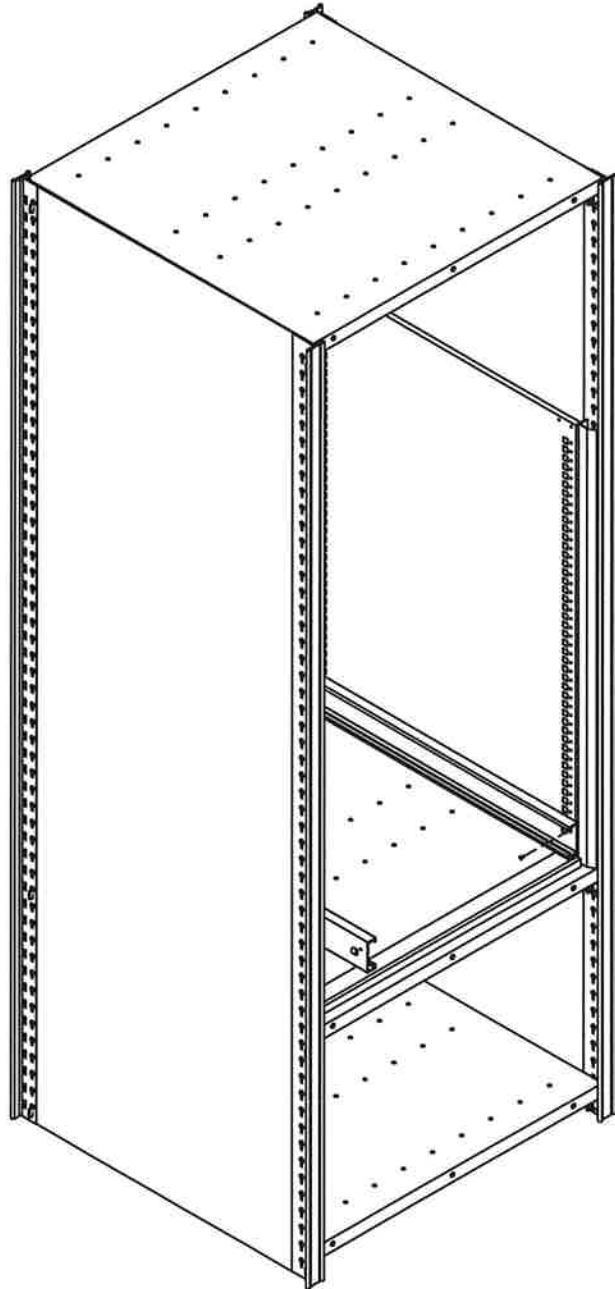

## STATIONARY SECTION OF SLIDE

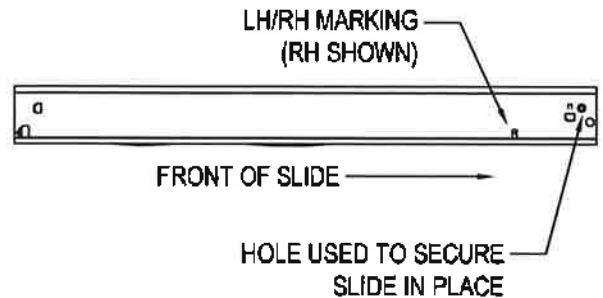

## MIDDLE SECTION OF SLIDE

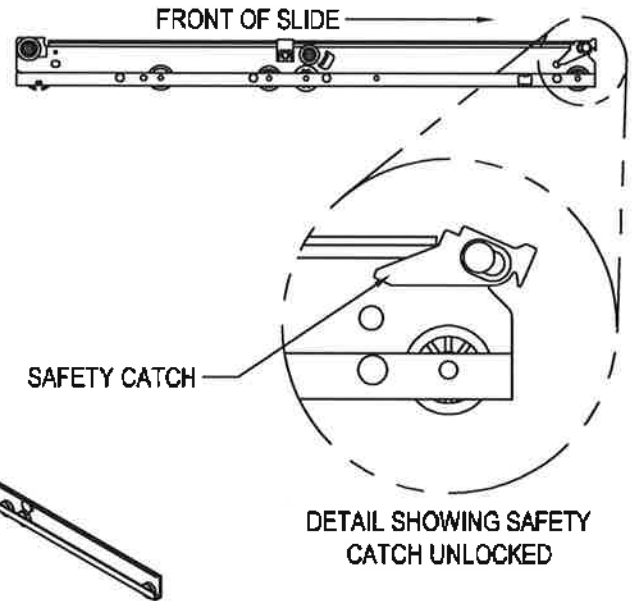

## REQUIRED HARDWARE:



#8-32 x 3/8"

FLAT HEAD TAPPING SCREW  
(2 PIECES) SUPPLIED WITH DRAWER

NOTE: DRAWER SLIDES ARE SUPPLIED WITH THE INDIVIDUAL DRAWERS

SHEET 4

**IN NEED OF  
ASSEMBLY ASSISTANCE?**

Contact us direct for fast friendly service (800) 323-0082

Int'l calls (630) 892-8941 | WEB: [www.lyonworkspace.com](http://www.lyonworkspace.com)

ASSEMBLY INSTRUCTIONS  
FOR LYON MODULAR  
DRAWERS IN SHELVING

**LYON**

LYON LLC.  
P.O. BOX 871  
AURORA, IL 60507

**9116-CA**

## ASSEMBLY OPERATION #4

1.) INSERT DRAWER INTO DRAWER SLIDES. THE DRAWER WILL NEED TO BE LIFTED OVER THE DRAWER STOPS DURING THIS PROCESS. AFTER THE DRAWER IS FULLY INSTALLED, ENSURE THE SAFETY CATCHES ARE LOCKED ON THE FRONT OF EACH SLIDE. THIS PREVENTS THE DRAWER FROM SLIPPING OVER THE DRAWER STOPS.

2.) CONTINUE TO INSTALL DRAWER SLIDES FOR THE REMAINING DRAWERS. THE SPACING IS DETERMINED BY THE HEIGHT OF THE DRAWER FRONT BELOW. THE NEXT DRAWER SLIDE SHOULD BE JUST ABOVE THE DRAWER FRONT BELOW.

\*\* REFER TO ASSEMBLY OPERATION #3 FOR MORE DETAILED INSTRUCTIONS ON DRAWER SLIDE INSTALLATION

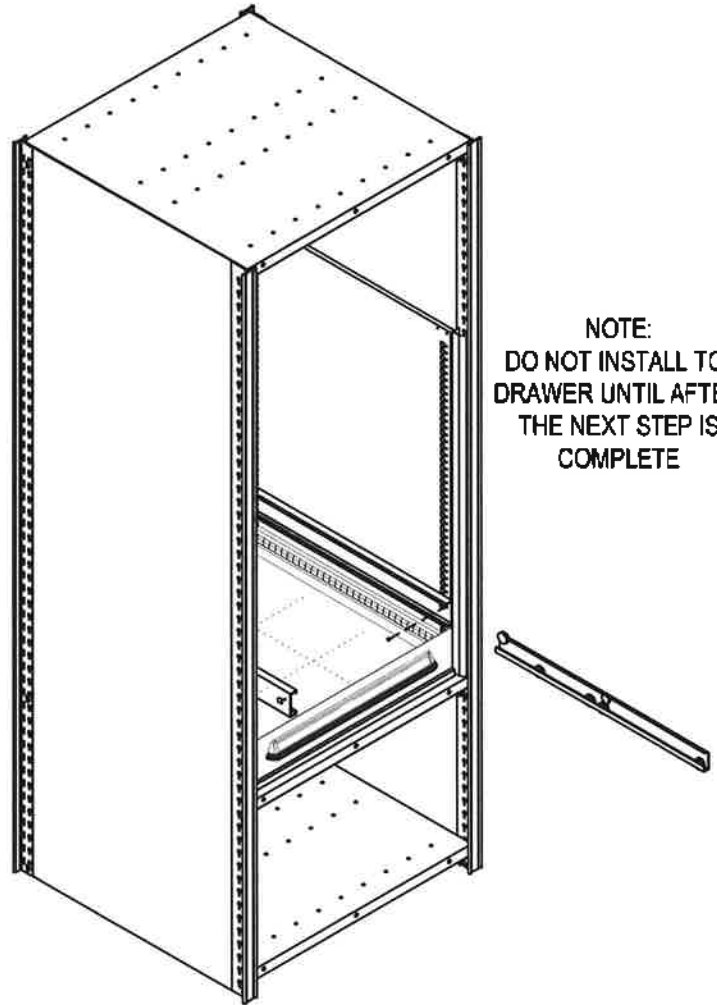
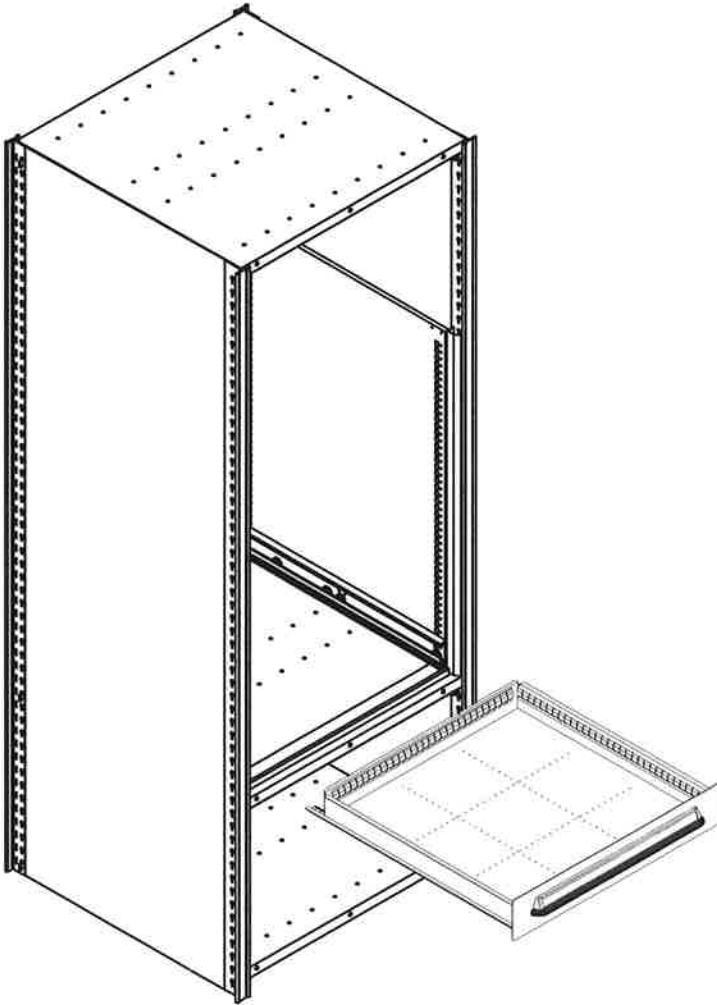

NOTE:  
DO NOT INSTALL TOP  
DRAWER UNTIL AFTER  
THE NEXT STEP IS  
COMPLETE

### REQUIRED HARDWARE:



#8-32 x 3/8"  
FLAT HEAD TAPPING SCREW  
(2 PER DRAWER) SUPPLIED WITH DRAWER

SHEET 5

## IN NEED OF ASSEMBLY ASSISTANCE?

Contact us direct for fast friendly service (800) 323-0082

Int'l calls (630) 892-8941 | WEB: [www.lyonworkspace.com](http://www.lyonworkspace.com)

ASSEMBLY INSTRUCTIONS  
FOR LYON MODULAR  
DRAWERS IN SHELVING

**LYON**

LYON L.L.C.  
P.O. BOX 871  
AURORA, IL 60507

**9116-CA**

## ASSEMBLY OPERATION #5

- 1.) WITH THE TOP DRAWER REMOVED, BUT WITH THE TOP DRAWER SLIDES IN PLACE, ASSEMBLE HORIZONTAL TRIM PIECE AT THE TOP OF THE UNIT. USE (4) #8 TAPPING SCREWS TO ATTACH.
  - 2.) INSTALL TOP DRAWER AND ENSURE SAFETY CATCHES ARE LOCKED TO PREVENT THE DRAWER FROM SLIPPING OVER THE DRAWER STOPS.
  - 3.) INSTALL SHELF DIRECTLY ABOVE MODULAR DRAWER UNIT, AND INSTALL ANY OTHER DESIRED SHELVES AT THIS TIME.
- IF DRAWER PARTITIONS AND DIVIDERS WERE ORDERED, THEY CAN BE INSTALLED AT THIS TIME.

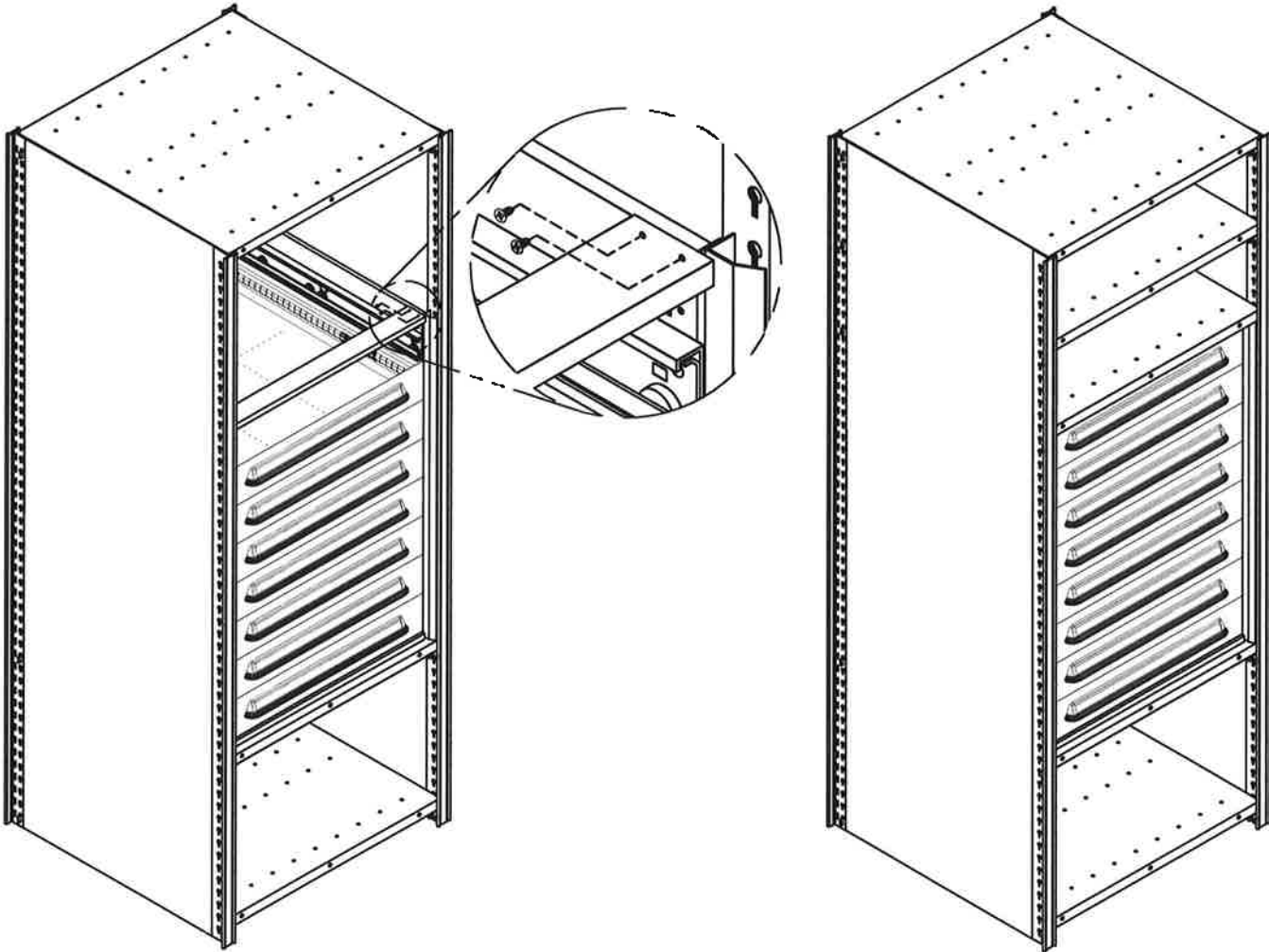

### REQUIRED HARDWARE:



#8-32 x 3/8"  
FLAT HEAD TAPPING SCREW  
(4 PIECES)

SHEET 6

## IN NEED OF ASSEMBLY ASSISTANCE?

Contact us direct for fast friendly service (800) 323-0082

Int'l calls (630) 892-8941 | WEB: [www.lyonworkspace.com](http://www.lyonworkspace.com)

ASSEMBLY INSTRUCTIONS  
FOR LYON MODULAR  
DRAWERS IN SHELVING

**LYON**

LYON L.L.C.  
P.O. BOX 871  
AURORA, IL 60507

**9116-CA**